

Feature

- 1.5V \pm 0.075V / 1.35V -0.0675V/+0.1V (JEDEC Standard Power Supply)
- 8 Internal memory banks (BA0- BA2)
- Differential clock input (CK, \overline{CK})
- Programmable \overline{CAS} Latency: 6, 7, 8, 9, 10, 11
- Programmable Additive Latency: 0, CL-1, CL-2
- Programmable Sequential / Interleave Burst Type
- Programmable Burst Length: 4, 8
- 8 bit prefetch architecture
- Output Driver Impedance Control
- Write Leveling
- OCD Calibration
- Dynamic ODT (Rtt_Nom & Rtt_WR)
- Auto Self-Refresh
- Self-Refresh Temperature
- RoHS compliance and Halogen free
- Packages:
 - 78-Ball BGA for x4 & x8 components
 - 96-Ball BGA for x16 components

Description

The 2Gb Double-Data-Rate-3 (DDR3) DRAMs is a high-speed CMOS Double Data Rate³² SDRAM containing 2,147,483,648 bits. It is internally configured as an octal-bank DRAM.

The 2Gb chip is organized as 64Mbit x 4 I/O x 8 bank, 32Mbit x 8 I/O x 8 bank or 16Mbit x 16 I/O x 8 bank device. These synchronous devices achieve high speed double-data-rate transfer rates of up to 1600 Mb/sec/pin for general applications.

The chip is designed to comply with all key DDR3 DRAM key features and all of the control and address inputs are synchronized with a pair of externally supplied differential clocks. Inputs are latched at the cross point of differential clocks (CK rising and \overline{CK} falling). All I/Os are synchronized with a single ended DQS or differential DQS pair in a source synchronous fashion.

These devices operate with a single 1.5V \pm 0.075V and 1.35V -0.0675V/+0.1V power supply and are available in BGA packages.

Part Number Information

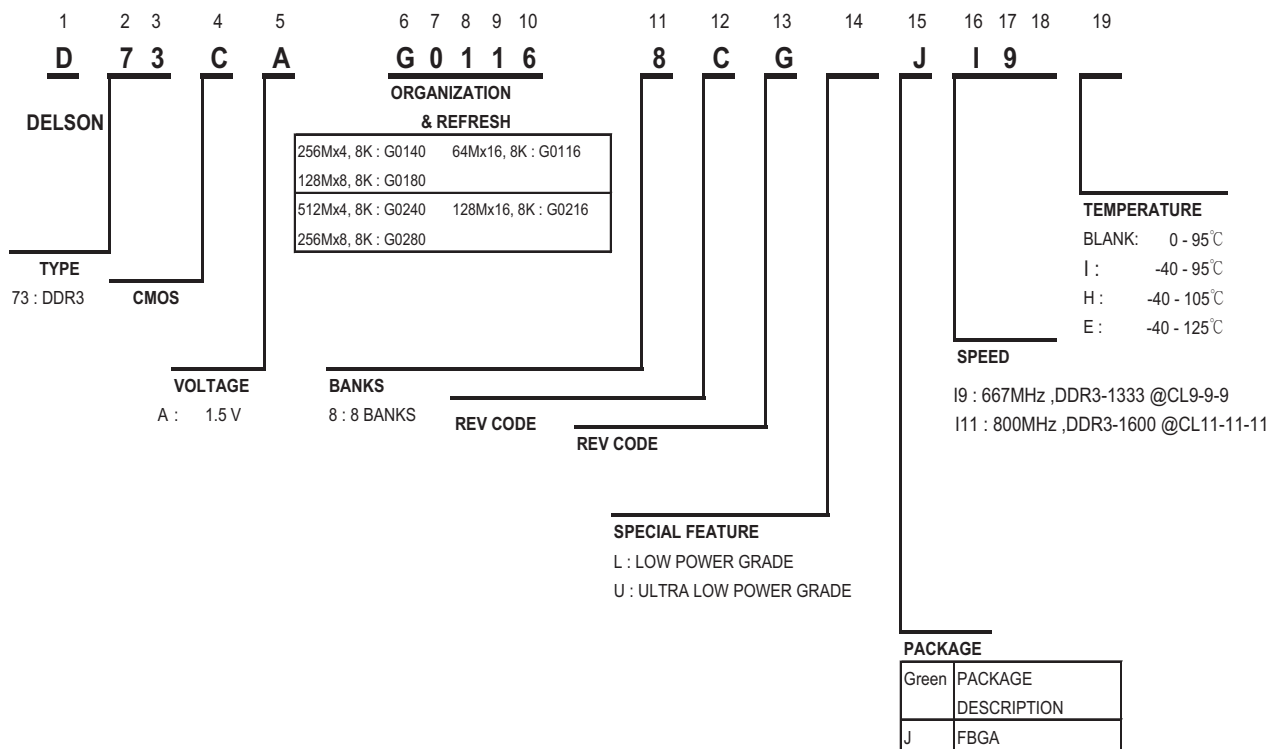

*GREEN: RoHS-compliant and Halogen-Free

Pin Configuration – 78 balls BGA Package (x8)

< TOP View >

See the balls through the package

x 8						
1	2	3		7	8	9
VSS	VDD	NC	A	NU/TDQS	VSS	VDD
VSS	VSSQ	DQ0	B	DM/TDQS	VSSQ	VDDQ
VDDQ	DQ2	DQS	C	DQ1	DQ3	VSSQ
VSSQ	DQ6	DQS	D	VDD	VSS	VSSQ
VREFDQ	VDDQ	DQ4	E	DQ7	DQ5	VDDQ
NC	VSS	RAS	F	CK	VSS	NC
ODT	VDD	CAS	G	CK	VDD	CKE
NC	CS	WE	H	A10/AP	ZQ	NC
VSS	BA0	BA2	J	NC	VERFCA	VSS
VDD	A3	A0	K	A12/ BC	BA1	VDD
VSS	A5	A2	L	A1	A4	VSS
VDD	A7	A9	M	A11	A6	VDD
VSS	RESET	A13	N	A14	A8	VSS

Pin Configuration – 96 balls BGA Package (x16)

< TOP View >

See the balls through the package

x 16						
1	2	3		7	8	9
VDDQ	DQU5	DQU7	A	DQU4	VDDQ	VSS
VSSQ	VDD	VSS	B	DQSU	DQU6	VSSQ
VDDQ	DQU3	DQU1	C	DQSU	DQU2	VDDQ
VSSQ	VDDQ	UDM	D	DQU0	VSSQ	VDD
VSS	VSSQ	DQL0	E	DML	VSSQ	VDDQ
VDDQ	DQL2	DQSL	F	DQL1	DQL3	VSSQ
VSSQ	DQL6	DQSL	G	VDD	VSS	VSSQ
VREFDQ	VDDQ	DQL4	H	DQL7	DQL5	VDDQ
NC	VSS	RAS	J	CK	VSS	NC
ODT	VDD	CAS	K	CK	VDD	CKE
NC	CS	WE	L	A10/AP	ZQ	NC
VSS	BA0	BA2	M	A15	VREFCA	VSS
VDD	A3	A0	N	A12/BC#	BA1	VDD
VSS	A5	A2	P	A1	A4	VSS
VDD	A7	A9	R	A11	A6	VDD
VSS	RESET	A13	T	A14	A8	VSS

Input / Output Functional Description

Symbol	Type	Function
CK, \overline{CK}	Input	Clock: CK and \overline{CK} are differential clock inputs. All address and control input signals are sampled on the crossing of the positive edge of CK and negative edge of \overline{CK} .
CKE	Input	Clock Enable: CKE high activates, and CKE low deactivates, internal clock signals and device input buffers and output drivers. Taking CKE low provides Precharge Power-Down and Self-Refresh operation (all banks idle), or Active Power-Down (row Active in any bank). CKE is synchronous for power down entry and exit and for Self-Refresh entry. CKE is asynchronous for Self-Refresh exit. After VREF has become stable during the power on and initialization sequence, it must be maintained for proper operation of the CKE receiver. For proper self-refresh entry and exit, VREF must maintain to this input. CKE must be maintained high throughout read and write accesses. Input buffers, excluding CK, \overline{CK} , ODT and CKE are disabled during Power Down. Input buffers, excluding CKE, are disabled during Self-Refresh.
\overline{CS}	Input	Chip Select: All commands are masked when \overline{CS} is registered high. \overline{CS} provides for external rank selection on systems with multiple memory ranks. \overline{CS} is considered part of the command code.
\overline{RAS} , \overline{CAS} , \overline{WE}	Input	Command Inputs: \overline{RAS} , \overline{CAS} and \overline{WE} (along with \overline{CS}) define the command being entered.
DM, (DMU, DML)	Input	Input Data Mask: DM is an input mask signal for write data. Input data is masked when DM is sampled HIGH coincident with that input data during a Write access. DM is sampled on both edges of DQS. For x8 device, the function of DM or TDQS / \overline{TQDS} is enabled by Mode Register A11 setting in MR1
BA0 - BA2	Input	Bank Address Inputs: BA0, BA1, and BA2 define to which bank an Active, Read, Write or Precharge command is being applied. Bank address also determines which mode register is to be accessed during a MRS cycle.
A0 – A14	Input	Address Inputs: Provide the row address for Activate commands and the column address for Read/Write commands to select one location out of the memory array in the respective bank. (A10/AP and A12/ \overline{BC} have additional function as below. The address inputs also provide the op-code during Mode Register Set commands.
A12 / \overline{BC}	Input	Burst Chop: A12/ \overline{BC} is sampled during Read and Write commands to determine if burst chop (on the fly) will be performed. (HIGH - no burst chop; LOW - burst chopped).
DQ	Input/output	Data Inputs/Output: Bi-directional data bus.
DQL, DQU, DQS,(\overline{DQS}), DQSL,(\overline{DQSL}), DQSU,(\overline{DQSU}),	Input/output	Data Strobe: output with read data, input with write data. Edge aligned with read data, centered with write data. The data strobes DQS, DQSL, DQSU are paired with differential signals \overline{DQS} , \overline{DQSL} , \overline{DQSU} , respectively, to provide differential pair signaling to the system during both reads and writes. DDR3 SDRAM supports differential data strobe only and does not support single-ended.

Symbol	Type	Function
ODT	Input	On Die Termination: ODT (registered HIGH) enables termination resistance internal to the DDR3 SDRAM. When enabled, ODT is applied to each DQ, DQS, \overline{DQS} and DM/TDQS, NU/ \overline{TDQS} (when TDQS is enabled via Mode Register A11=1 in MR1) signal for x8 configurations. The ODT pin will be ignored if Mode-registers, MR1 and MR2, are programmed to disable RTT.
\overline{RESET}	Input	Active Low Asynchronous Reset: Reset is active when \overline{RESET} is LOW, and inactive when \overline{RESET} is HIGH. \overline{RESET} must be HIGH during normal operation. \overline{RESET} is a CMOS rail to rail signal with DC high and low at 80% and 20% of VDD, i.e. 1.20V for DC high and 0.30V
NC		No Connect: No internal electrical connection is present.
VDDQ	Supply	DQ Power Supply: 1.5V \pm 0.075V , 1.35V -0.0675V/+0.1V
VDD	Supply	Power Supply: 1.5V \pm 0.075V, 1.35V -0.0675V/+0.1V
VSSQ	Supply	DQ Ground
Vss	Supply	Ground
VREFCA	Supply	Reference voltage for CA
VREFDQ	Supply	Reference voltage for DQ
ZQ	Supply	Reference pin for ZQ calibration.

Note: Input only pins (BA0-BA2, A0-A13, \overline{RAS} , \overline{CAS} , \overline{WE} , \overline{CS} , CKE, ODT, and \overline{RESET}) do not supply termination.

Simplified State Diagram

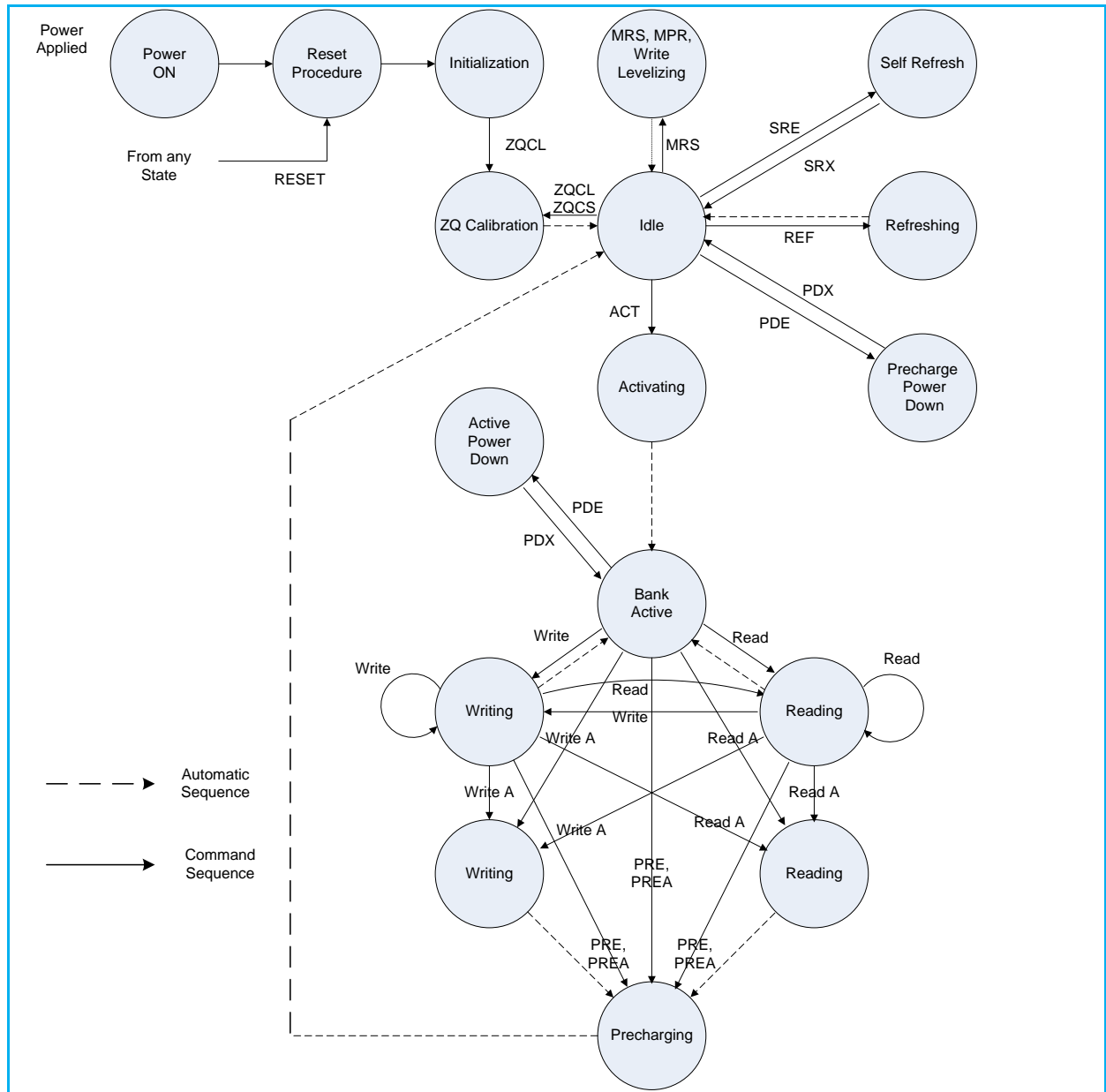

Abbreviation	Function	Abbreviation	Function	Abbreviation	Function
ACT	Active	Read	RD, RDS4, RDS8	PED	Enter Power-down
PRE	Precharge	Read A	RDA, RDAS4, RDAS8	PDX	Exit Power-down
PREA	Precharge All	Write	WR, WRS4, WRS8	SRE	Self-Refresh entry
MRS	Mode Register Set	Write A	WRA, WRAS4, WRAS8	SRX	Self-Refresh exit
REF	Refresh	$\overline{\text{RESET}}$	Start RESET Procedure	MPR	Multi-Purpose Register
ZQCL	ZQ Calibration Long	ZQCS	ZQ Calibration Short	-	-

Basic Functionality

The DDR3 SDRAM is a high-speed dynamic random access memory internally configured as an eight-bank DRAM. The DDR3 SDRAM uses an 8n prefetch architecture to achieve high speed operation. The 8n prefetch architecture is combined with an interface designed to transfer two data words per clock cycle at the I/O pins. A single read or write operation for the DDR3 SDRAM consists of a single 8n-bit wide, four clock data transfer at the internal DRAM core and two corresponding n-bit wide, one-half clock cycle data transfers at the I/O pins.

Read and write operation to the DDR3 SDRAM are burst oriented, start at a selected location, and continue for a burst length of eight or a 'chopped' burst of four in a programmed sequence. Operation begins with the registration of an Active command, which is then followed by a Read or Write command. The address bits registered coincident with the Active command are used to select the bank and row to be activated (BA0-BA2 select the bank; A0-A13 select the row). The address bit registered coincident with the Read or Write command are used to select the starting column location for the burst operation, determine if the auto precharge command is to be issued (via A10), and select BC4 or BC8 mode 'on the fly' (via A12) if enabled in the mode register.

Prior to normal operation, the DDR3 SDRAM must be powered up and initialized in a predefined manner. The following sections provide detailed information covering device reset and initialization, register definition, command descriptions and device operation.

DRAM Initialization and RESET

Power-up Initialization sequence

The Following sequence is required for POWER UP and Initialization

1. Apply power ($\overline{\text{RESET}}$ is recommended to be maintained below $0.2 \times V_{DD}$, all other inputs may be undefined). $\overline{\text{RESET}}$ needs to be maintained for minimum 200 μ s with stable power. CKE is pulled "Low" anytime before $\overline{\text{RESET}}$ being de-asserted (min. time 10ns). The power voltage ramp time between 300mV to $V_{DD_{min}}$ must be no greater than 200ms; and during the ramp, $V_{DD} > V_{DDQ}$ and $(V_{DD} - V_{DDQ}) < 0.3$ Volts.
 - VDD and VDDQ are driven from a single power converter output, AND
 - The voltage levels on all pins other than VDD, VDDQ, VSS, VSSQ must be less than or equal to VDDQ and VDD on one side and must be larger than or equal to VSSQ and VSS on the other side. In addition, VTT is limited to 0.95V max once power ramp is finished, AND
 - V_{ref} tracks $V_{DDQ}/2$.
- OR
 - Apply VDD without any slope reversal before or at the same time as VDDQ.
 - Apply VDDQ without any slope reversal before or at the same time as VTT & V_{ref} .
 - The voltage levels on all pins other than VDD, VDDQ, VSS, VSSQ must be less than or equal to VDDQ and VDD on one side and must be larger than or equal to VSSQ and VSS on the other side.
2. After $\overline{\text{RESET}}$ is de-asserted, wait for another 500us until CKE become active. During this time, the DRAM will start internal state initialization; this will be done independently of external clocks.
3. Clock (CK, $\overline{\text{CK}}$) need to be started and stabilized for at least 10ns or $5t_{CK}$ (which is larger) before CKE goes active. Since CKE is a synchronous signal, the corresponding set up time to clock (t_{IS}) must be meeting. Also a NOP or Deselect command must be registered (with t_{IS} set up time to clock) before CKE goes active. Once the CKE registered "High" after Reset, CKE needs to be continuously registered "High" until the initialization sequence is finished, including expiration of t_{DLLK} and t_{ZQinit} .

4. The DDR3 DRAM will keep its on-die termination in high impedance state as long as $\overline{\text{RESET}}$ is asserted. Further, the DRAM keeps its on-die termination in high impedance state after $\overline{\text{RESET}}$ de-assertion until CKE is registered HIGH. The ODT input signal may be in undefined state until tIS before CKE is registered HIGH. When CKE is registered HIGH, the ODT input signal may be statically held at either LOW or HIGH. If RTT_NOM is to be enabled in MR1, the ODT input signal must be statically held LOW. In all cases, the ODT input signal remains static until the power up initialization sequence is finished, including the expiration of tDLLK and tZQinit.
5. After CKE being registered high, wait minimum of Reset CKE Exit time, tXPR, before issuing the first MRS command to load mode register. [tXPR=max(tXS, 5tCK)]
6. Issue MRS command to load MR2 with all application settings. (To issue MRS command for MR2, provide “Low” to BA0 and BA2, “High” to BA1)
7. Issue MRS command to load MR3 with all application settings. (To issue MRS command for MR3, provide “Low” to BA2, “High” to BA0 and BA1)
8. Issue MRS command to load MR1 with all application settings and DLL enabled. (To issue “DLL Enable” command, provide “Low” to A0, “High” to BA0 and “Low” to BA1 and BA2)
9. Issue MRS Command to load MR0 with all application settings and “DLL reset”. (To issue DLL reset command, provide “High” to A8 and “Low” to BA0-BA2)
10. Issue ZQCL command to starting ZQ calibration.
11. Wait for both t_{DLLK} and t_{ZQinit} completed.
12. The DDR3 SDRAM is now ready for normal operation.

DDR3 Reset and Initialization Sequence at Power-on Ramping

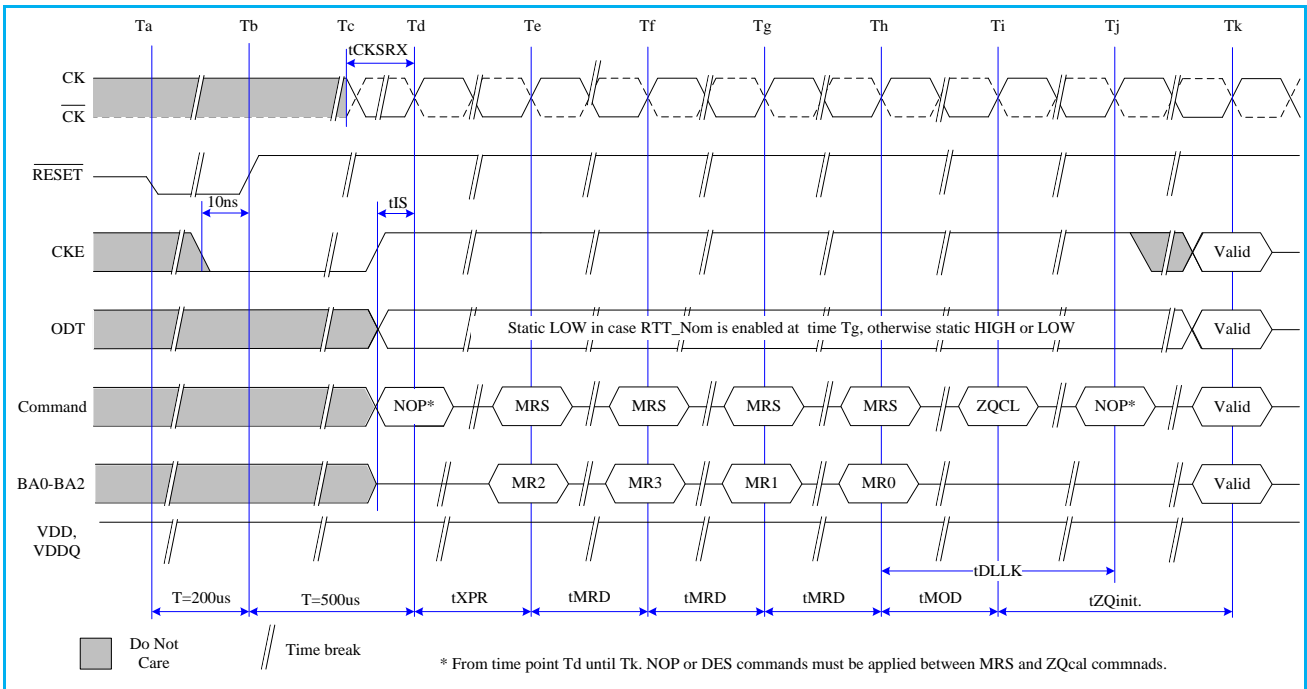

DDR3 Reset Procedure at Power Stable Condition

The following sequence is required for RESET at no power interruption initialization.

1. Asserted RESET below $0.2 \cdot VDD$ anytime when reset is needed (all other inputs may be undefined). RESET needs to be maintained for minimum 100ns. CKE is pulled "Low" before RESET being de-asserted (min. time 10ns).
2. Follow Power-up Initialization Sequence step 2 to 11.
3. The Reset sequence is now completed. DDR3 SDRAM is ready for normal operation.

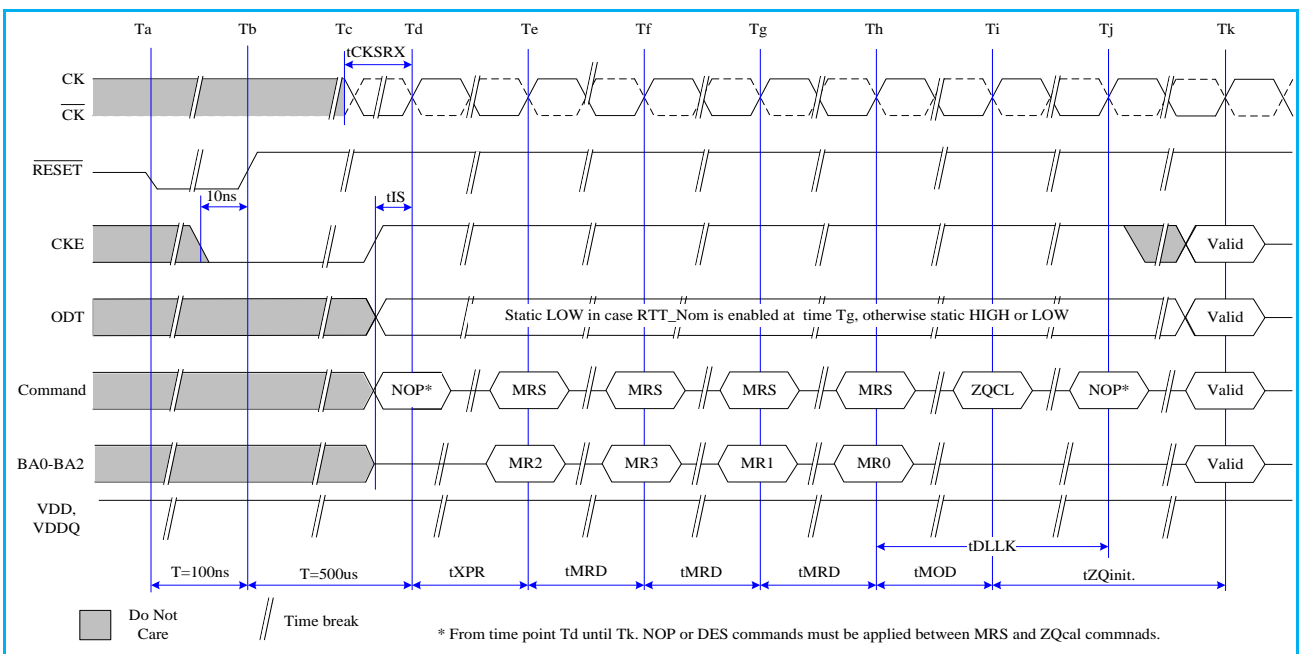

Register Definition

Programming the Mode Registers

For application flexibility, various functions, features, and modes are programmable in four Mode Registers, provided by the DDR3 SDRAM, as user defined variables and they must be programmed via a Mode Register Set (MRS) command. As the default values of the Mode Registers (MR#) are not defined, contents of Mode Registers must be fully initialized and/or re-initialized, i.e. written, after power up and/or reset for proper operation. Also the contents of the Mode Registers can be altered by re-executing the MRS command during normal operation. When programming the mode registers, even if the user chooses to modify only a sub-set of the MRS fields, all address fields within the accessed mode register must be redefined when the MRS command is issued. MRS command and DLL Reset do not affect array contents, which means these commands can be executed any time after power-up without affecting the array contents

The mode register set command cycle time, t_{MRD} is required to complete the write operation to the mode register and is the minimum time required between two MRS commands shown as below.

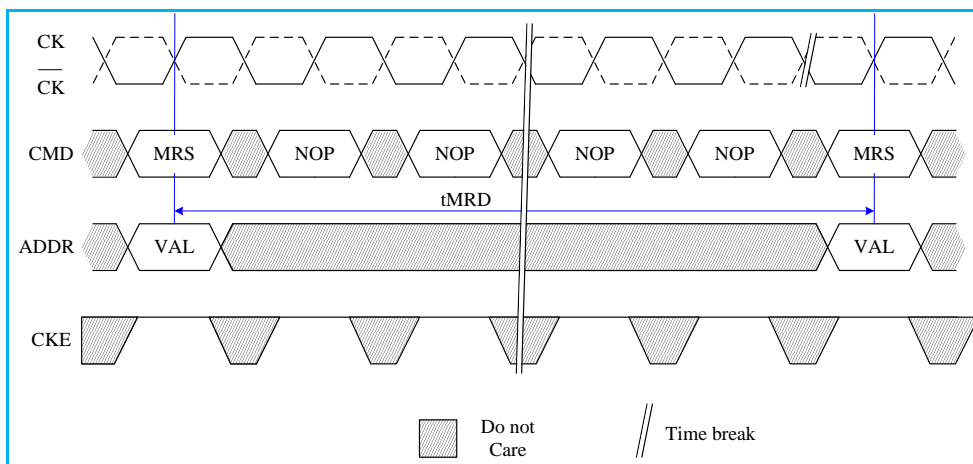

The MRS command to Non-MRS command delay, t_{MOD} , is required for the DRAM to update the features except DLL reset, and is the minimum time required from an MRS command to a non-MRS command excluding NOP and DES shown as the following figure.

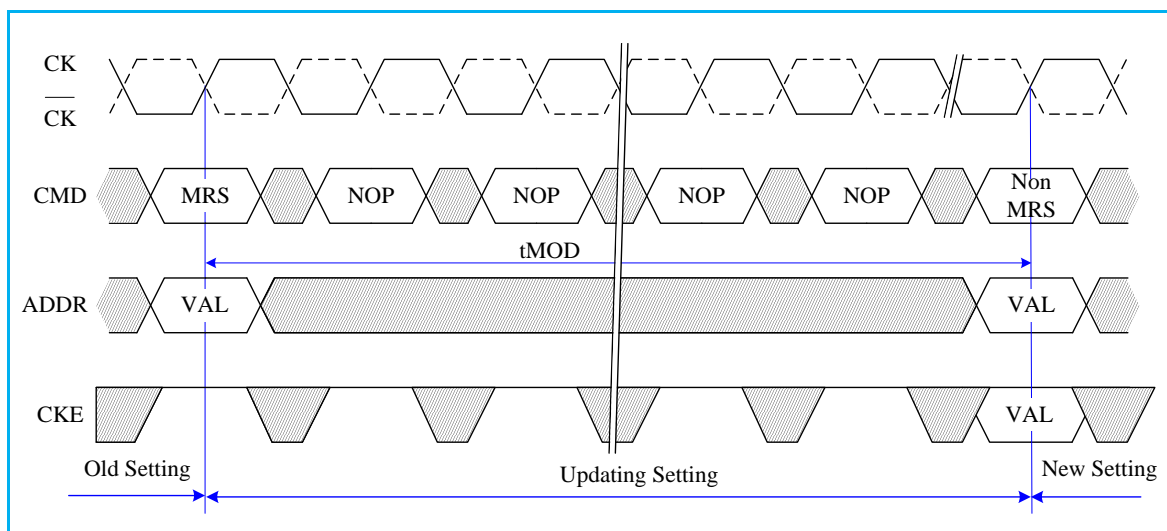

The mode register contents can be changed using the same command and timing requirements during normal operation as long as the DRAM is in idle state, i.e. all banks are in the precharged state with tRP satisfied, all data bursts are completed and CKE is high prior to writing into the mode register. The mode registers are divided into various fields depending on the functionality and/or modes.

The mode-register MR0 stores data for controlling various operating modes of DDR3 SDRAM. It controls burst length, read burst type, CAS latency, test mode, DLL reset, WR, and DLL control for precharge Power-Down, which include various vendor specific options to make DDR3 SDRAM useful for various applications. The mode register is written by asserting low on \overline{CS} , \overline{RAS} , \overline{CAS} , \overline{WE} , BA0, BA1, and BA2, while controlling the states of address pins according to the following figure.

MR0 Definition

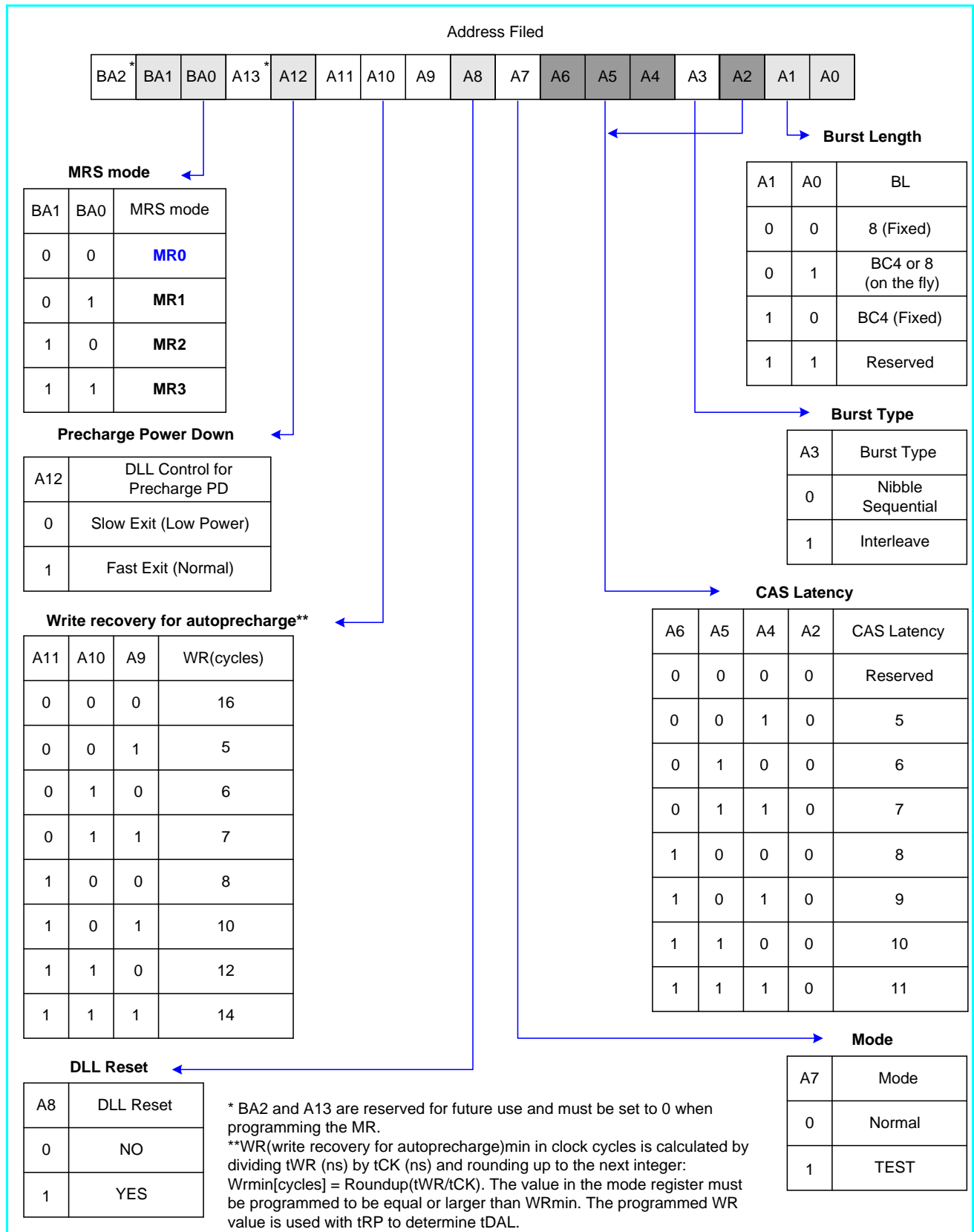

Burst Length, Type, and Order

Accesses within a given burst may be programmed to sequential or interleaved order. The burst type is selected via bit A3 as shown in the MR0 Definition as above figure. The ordering of access within a burst is determined by the burst length, burst type, and the starting column address. The burst length is defined by bits A0-A1. Burst lengths options include fix BC4, fixed BL8, and on the fly which allow BC4 or BL8 to be selected coincident with the registration of a Read or Write command via A12/ \overline{BC} .

Burst Type and Burst Order

Burst Length	Read Write	Starting Column Address (A2,A1,A0)	Burst type: Sequential (decimal) A3 = 0	Burst type: Interleaved (decimal) A3 = 1	Note
4 Chop	Read	0 , 0 , 0	0,1,2,3,T,T,T,T	0,1,2,3,T,T,T,T	1,2,3
		0 , 0 , 1	1,2,3,0,T,T,T,T	1,0,3,2,T,T,T,T	
		0 , 1 , 0	2,3,0,1,T,T,T,T	2,3,0,1,T,T,T,T	
		0 , 1 , 1	3,0,1,2,T,T,T,T	3,2,1,0,T,T,T,T	
		1 , 0 , 0	4,5,6,7,T,T,T,T	4,5,6,7,T,T,T,T	
		1 , 0 , 1	5,6,7,4,T,T,T,T	5,4,7,6,T,T,T,T	
		1 , 1 , 0	6,7,4,5,T,T,T,T	6,7,4,5,T,T,T,T	
		1 , 1 , 1	7,4,5,6,T,T,T,T	7,6,5,4,T,T,T,T	
	Write	0 , V , V	0,1,2,3,X,X,X,X	0,1,2,3,X,X,X,X	1,2,4,5
		1 , V , V	4,5,6,7,X,X,X,X	4,5,6,7,X,X,X,X	
8	Read	0 , 0 , 0	0,1,2,3,4,5,6,7	0,1,2,3,4,5,6,7	2
		0 , 0 , 1	1,2,3,0,5,6,7,4	1,0,3,2,5,4,7,6	
		0 , 1 , 0	2,3,0,1,6,7,4,5	2,3,0,1,6,7,4,5	
		0 , 1 , 1	3,0,1,2,7,4,5,6	3,2,1,0,7,6,5,4	
		1 , 0 , 0	4,5,6,7,0,1,2,3	4,5,6,7,0,1,2,3	
		1 , 0 , 1	5,6,7,4,1,2,3,0	5,4,7,6,1,0,3,2	
		1 , 1 , 0	6,7,4,5,2,3,0,1	6,7,4,5,2,3,0,1	
	1 , 1 , 1	7,4,5,6,3,0,1,2	7,6,5,4,3,2,1,0		
Write	V , V , V	0,1,2,3,4,5,6,7	0,1,2,3,4,5,6,7	2,4	

Note:

1. In case of burst length being fixed to 4 by MR0 setting, the internal write operation starts two clock cycles earlier than the BL8 mode. This means that the starting point for tWR and tWTR will be pulled in by two clocks. In case of burst length being selected on-the-fly via A12/ \overline{BC} , the internal write operation starts at the same point in time like a burst of 8 write operation. This means that during on-the-fly control, the starting point for tWR and tWTR will not be pulled in by two clocks.
2. 0~7 bit number is value of CA[2:0] that causes this bit to be the first read during a burst.
3. T: Output driver for data and strobes are in high impedance.
4. V: a valid logic level (0 or 1), but respective buffer input ignores level on input pins.
5. X: Do not Care.

CAS Latency

The CAS Latency is defined by MR0 (bit A9~A11) as shown in the MR0 Definition figure. CAS Latency is the delay, in clock cycles, between the internal Read command and the availability of the first bit of output data. DDR3 SDRAM does not support any half clock latencies. The overall Read Latency (RL) is defined as Additive Latency (AL) + CAS Latency (CL); $RL = AL + CL$.

Test Mode

The normal operating mode is selected by MR0 (bit7=0) and all other bits set to the desired values shown in the MR0 definition figure. Programming bit A7 to a '1' places the DDR3 SDRAM into a test mode that is only used by the DRAM manufacturer and should not be used. No operations or functionality is guaranteed if A7=1.

DLL Reset

The DLL Reset bit is self-clearing, meaning it returns back to the value of '0' after the DLL reset function has been issued. Once the DLL is enabled, a subsequent DLL Reset should be applied. Anytime the DLL reset function is used, tDLLK must be met before any functions that require the DLL can be used (i.e. Read commands or ODT synchronous operations.)

Write Recovery

The programmed WR value MR0(bits A9, A10, and A11) is used for the auto precharge feature along with tRP to determine tDAL WR (write recovery for auto-precharge)min in clock cycles is calculated by dividing tWR(ns) by tCK(ns) and rounding up to the next integer: $WR_{min}[cycles] = Roundup(tWR[ns]/tCK[ns])$. The WR must be programmed to be equal or larger than tWR(min).

Precharge PD DLL

MR0 (bit A12) is used to select the DLL usage during precharge power-down mode. When MR0 (A12=0), or 'slow-exit', the DLL is frozen after entering precharge power-down (for potential power savings) and upon exit requires tXPDLL to be met prior to the next valid command. When MR0 (A12=1), or 'fast-exit', the DLL is maintained after entering precharge power-down and upon exiting power-down requires tXP to be met prior to the next valid command.

Mode Register MR1

The Mode Register MR1 stores the data for enabling or disabling the DLL, output strength, Rtt_Nom impedance, additive latency, WRITE leveling enable and Qoff. The Mode Register 1 is written by asserting low on \overline{CS} , \overline{RAS} , \overline{CAS} , \overline{WE} high on BA0 and low on BA1 and BA2, while controlling the states of address pins according to the following figure.

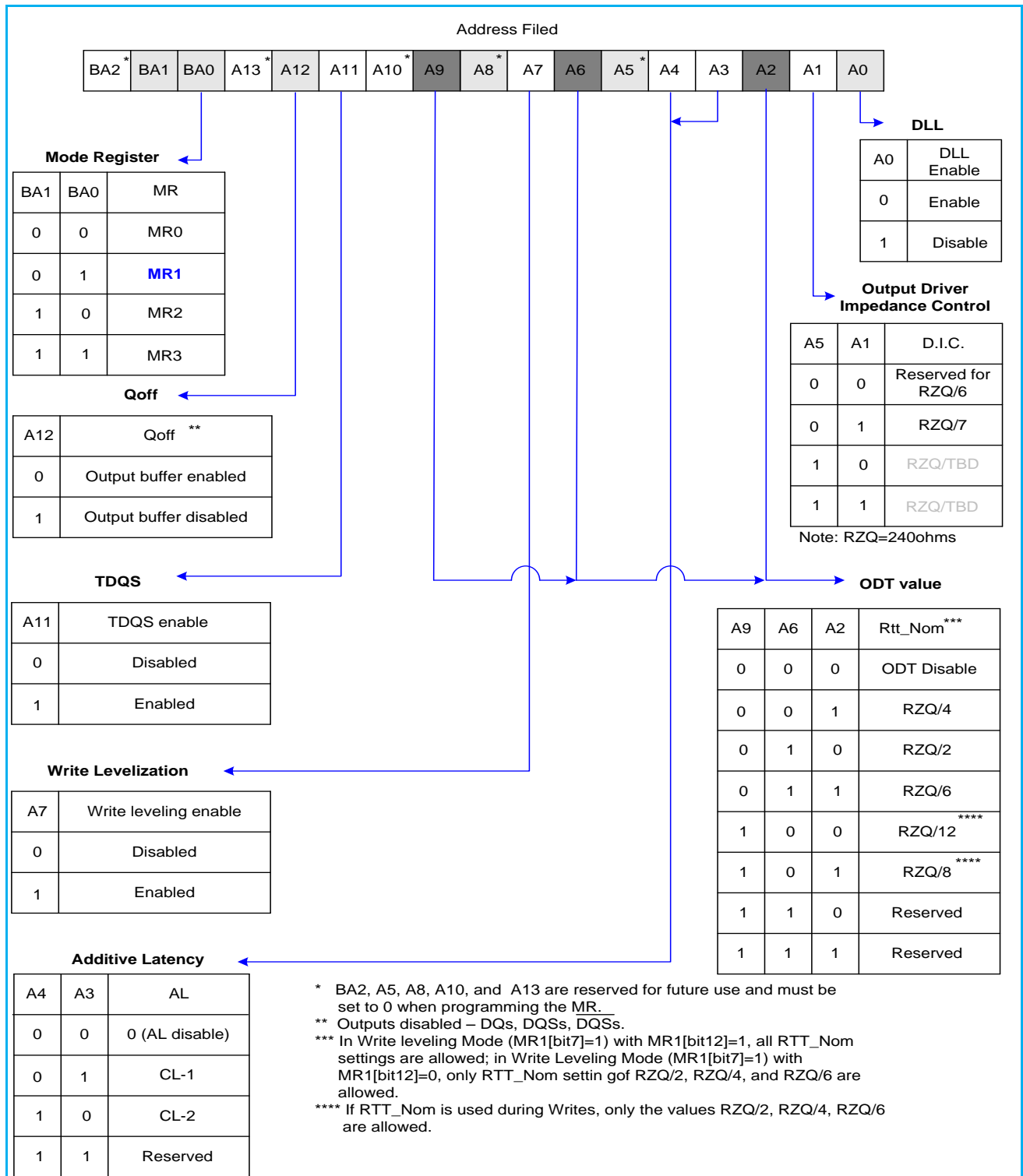

DLL Enable/Disable

The DLL must be enabled for normal operation. DLL enable is required during power up initialization, and upon returning to normal operation after having the DLL disabled. During normal operation (DLL-on) with MR1 (A0=0), the DLL is automatically disabled when entering Self-Refresh operation and is automatically re-enable upon exit of Self-Refresh operation. Any time the DLL is enabled and subsequently reset, tDLLK clock cycles must occur before a Read or synchronous ODT command can be issued to allow time for the internal clock to be synchronized with the external clock. Failing to wait for synchronization to occur may result in a violation of the tDQSCK, tAON, or tAOF parameters. During tDLLK, CKE must continuously be registered high. DDR3 SDRAM does not require DLL for any Write operation, expect when RTT_WR is enabled and the DLL is required for proper ODT operation. For more detailed information on DLL Disable operation in DLL-off Mode.

The direct ODT feature is not supported during DLL-off mode. The on-die termination resistors must be disabled by continuously registering the ODT pin low and/or by programming the RTT_Nom bits MR1{A9,A6,A2} to {0,0,0} via a mode register set command during DLL-off mode.

The dynamic ODT feature is not supported at DLL-off mode. User must use MRS command to set Rtt_WR, MR2{A10,A9}={0,0}, to disable Dynamic ODT externally.

Output Driver Impedance Control

The output driver impedance of the DDR3 SDRAM device is selected by MR1(bit A1 and A5) as shown in MR1 definition figure.

ODT Rtt Values

DDR3 SDRAM is capable of providing two different termination values (Rtt_Nom and Rtt_WR). The nominal termination value Rtt_Nom is programmable in MR1. A separate value (Rtt_WR) may be programmable in MR2 to enable a unique Rtt value when ODT is enabled during writes. The Rtt_WR value can be applied during writes even when Rtt_Nom is disabled.

Additive Latency (AL)

Additive Latency (AL) operation is supported to make command and data bus efficient for sustainable bandwidth in DDR3 SDRAM. In this operation, the DDR3 SDRAM allows a read or write command (either with or without auto-precharge) to be issued immediately after the active command. The command is held for the time of the Additive Latency (AL) before it is issued inside the device. The Read Latency (RL) is controlled by the sum of the AL and CAS Latency (CL) register settings. Write Latency (WL) is controlled by the sum of the AL and CAS Write Latency (CWL) register settings. A summary of the AL register options are shown as the following table.

Additive Latency (AL) Settings

A4	A3	AL
0	0	0, (AL Disable)
0	1	CL-1
1	0	CL-2
1	1	Reserved

Write leveling

For better signal integrity, DDR3 memory module adopted fly by topology for the commands, addresses, control signals, and clocks. The fly by topology has benefits from reducing number of stubs and their length but in other aspect, causes flight time skew between clock and strobe at every DRAM on DIMM. It makes difficult for the Controller to maintain tDQSS, tDSS, and tDSH specification. Therefore, the controller should support 'write leveling' in DDR3 SDRAM to compensate for skew.

Output Disable

The DDR3 SDRAM outputs maybe enable/disable by MR1 (bit12) as shown in MR1 definition. When this feature is enabled (A12=1) all output pins (DQs, DQS, \overline{DQS} , etc.) are disconnected from the device removing any loading of the output drivers. This feature may be useful when measuring modules power for example. For normal operation A12 should be set to '0'.

TDQS, \overline{TDQS}

TDQS (Termination Data Strobe) is a feature of x8 DDR3 SDRAM that provides additional termination resistance outputs that may be useful in some system configurations.

TDQS is not supported in x4 configurations. When enabled via the mode register, the same termination resistance function is applied to be TDQS/ \overline{TDQS} pins that are applied to the DQS/ \overline{DQS} pins.

In contrast to the RDQS function of DDR2 SDRAM, TDQS provides the termination resistance function only. The data strobe function of RDQS is not provided by TDQS.

The TDQS and DM functions share the same pin. When the TDQS function is enabled via the mode register, the DM function is not supported. When the TDQS function is disabled, the DM function is provided and the \overline{TDQS} pin is not used.

The TDQS function is available in x8 DDR3 SDRAM only and must be disabled via the mode register A11=0 in MR1 for x4 configurations.

TDQS, \overline{TDQS} Function Matrix

MR1 (A11)	DM / TDQS	NU / TDQS
0 (TDQS Disabled)	DM	Hi-Z
1 (TDQS Enabled)	TDQS	TDQS
Note:		
1. If TDQS is enabled, the DM function is disabled.		
2. When not used, TDQS function can be disabled to save termination power.		
3. TDQS function is only available for x8 DRAM and must be disabled for x4		

Mode Register MR2

The Mode Register MR2 stores the data for controlling refresh related features, Rtt_WR impedance, and CAS write latency. The Mode Register 2 is written by asserting low on \overline{CS} , \overline{RAS} , \overline{CAS} , \overline{WE} high on BA1 and low on BA0 and BA2, while controlling the states of address pins according to the table below.

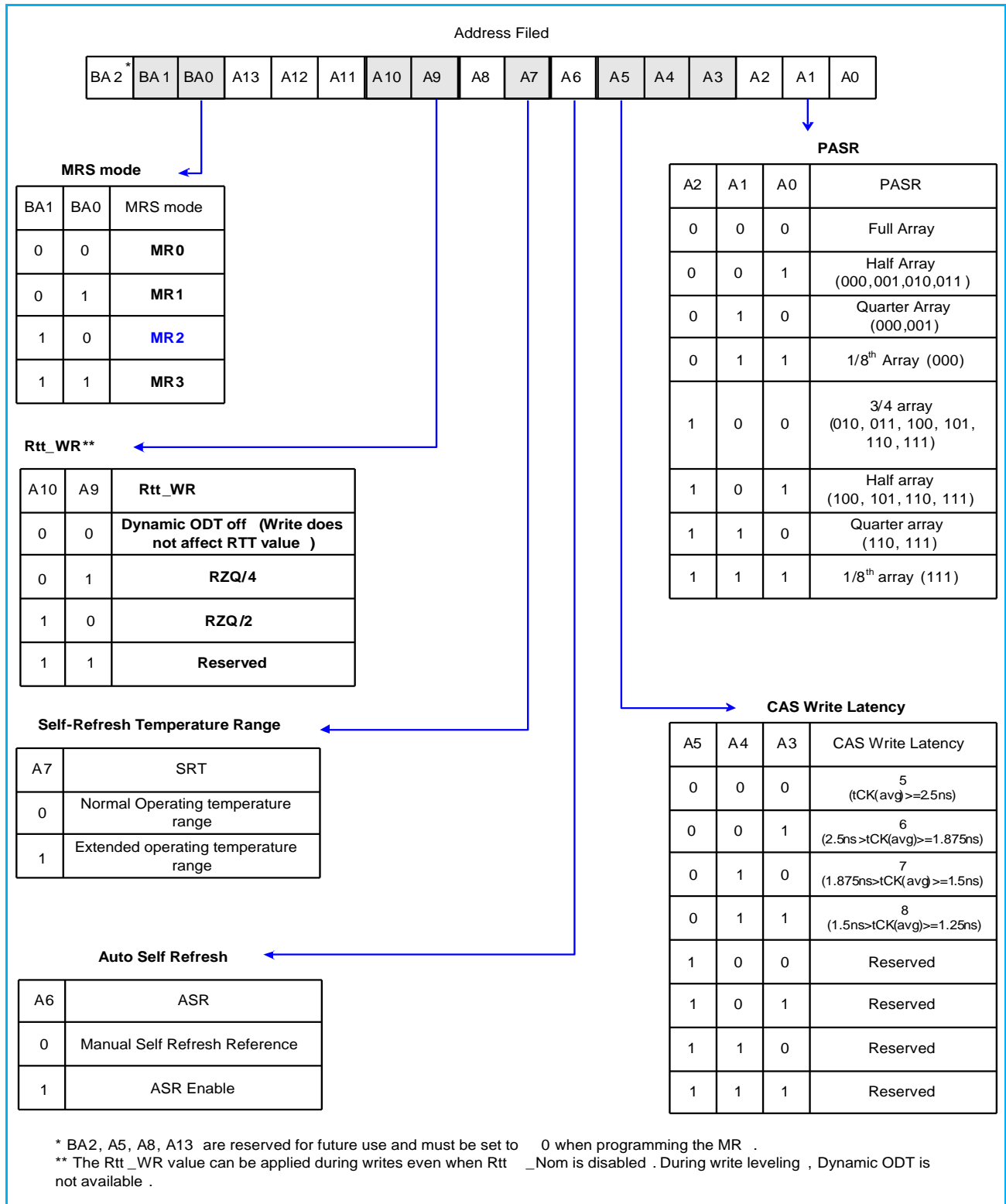

CAS Write Latency (CWL)

The CAS Write Latency is defined by MR2 (bits A3-A5) shown in MR2. CAS Write Latency is the delay, in clock cycles, between the internal Write command and the availability of the first bit of input data. DDR3 DRAM does not support any half clock latencies. The overall Write Latency (WL) is defined as Additive Latency (AL) + CAS Write Latency (CWL); $WL=AL+CWL$.

Auto Self-Refresh (ASR) and Self-Refresh Temperature (SRT)

DDR3 SDRAM must support Self-Refresh operation at all supported temperatures. Applications requiring Self-Refresh operation in the Extended Temperature Range must use the ASR function or program the SRT bit appropriately.

Optional in DDR3 SDRAM: Users should refer to the DRAM supplier data sheet and/or the DIMM SPD to determine if DDR3 SDRAM devices support the following options or requirements referred to in this material. For more details refer to “Extended Temperature Usage” on page48. DDR3 SDRAMs must support Self-Refresh operation at all supported temperatures. Applications requiring Self-Refresh operation in the Extended Temperature Range must use the optional ASR function or program the SRT bit appropriately.

Dynamic ODT (Rtt_WR)

DDR3 SDRAM introduces a new feature “Dynamic ODT”. In certain application cases and to further enhance signal integrity on the data bus, it is desirable that the termination strength of the DDR3 SDRAM can be changed without issuing an MRS command. MR2 Register locations A9 and A10 configure the Dynamic ODT settings

Mode Register MR3

The Mode Register MR3 controls Multi-purpose registers. The Mode Register 3 is written by asserting low on \overline{CS} , \overline{RAS} , \overline{CAS} , \overline{WE} high on BA1 and BA0, and low on BA2 while controlling the states of address pins according to the table below.

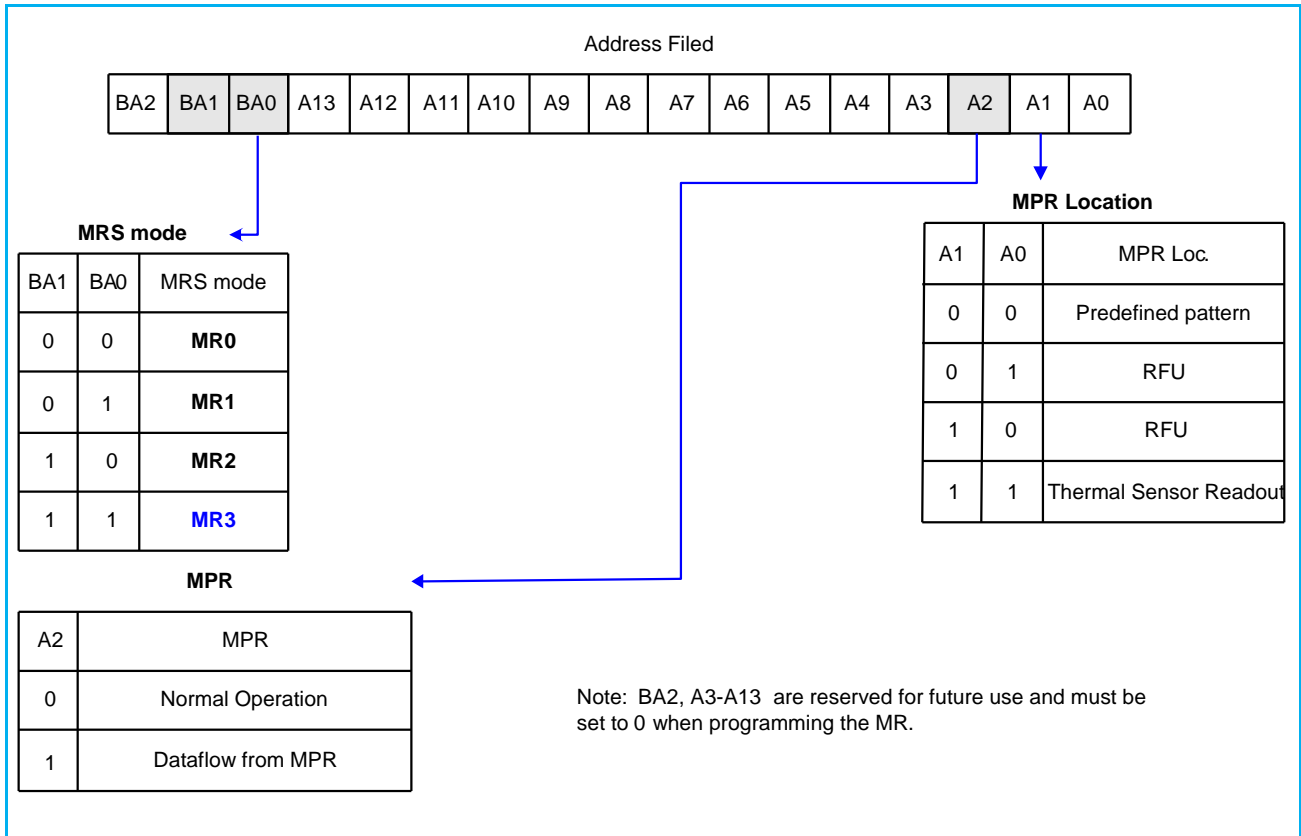

Multi-Purpose Register (MPR)

The Multi Purpose Register (MPR) function is used to Read out a predefined system timing calibration bit sequence. To enable the MPR, a Mode Register Set (MRS) command must be issued to MR3 register with bit A2=1. Prior to issuing the MRS command, all banks must be in the idle state (all banks precharged and tRP met). Once the MPR is enabled, any subsequent RD or RDA commands will be redirected to the Multi Purpose Register. When the MPR is enabled, only RD or RDA commands are allowed until a subsequent MRS command is issued with the MPR disabled (MR3 bit A2=0). Power down mode, Self-Refresh and any other non-RD/RDA command is not allowed during MPR enable mode. The RESET function is supported during MPR enable mode.

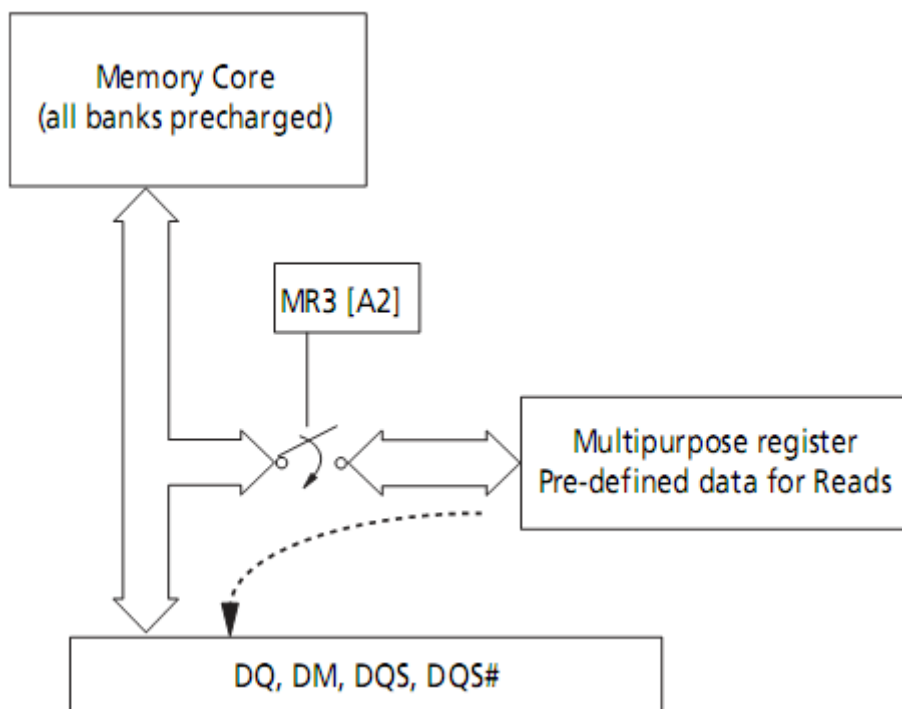

To enable the MPR, a MODE Register Set (MRS) command must be issued to MR3 Register with bit A2 = 1, as shown in Table12. Prior to issuing the MRS command, all banks must be in the idle state (all banks precharged and tRP met). Once the MPR is enabled, any subsequent RD or RDA commands will be redirected to the Multi Purpose Register. The resulting operation, when a RD or RDA command is issued, is defined by MR3 bits A[1:0] when the MPR is enabled as shown in Table13. When the MPR is enabled, only RD or RDA commands are allowed until a subsequent MRS command is issued with the MPR disabled (MR3 bit A2 = 0). Note that in MPR mode RDA has the same functionality as a READ command which means the auto precharge part of RDA is ignored. Power-Down mode, Self-Refresh and any other non-RD/RDA command is not allowed during MPR enable mode. The RESET function is supported during MPR enable mode.

DDR3 SDRAM Command Description and Operation

Command Truth Table (Conti.)

NOTE1. All DDR3 SDRAM commands are defined by states of \overline{CS} , \overline{RAS} , \overline{CAS} , \overline{WE} and CKE at the rising edge of the clock.

The MSB of BA, RA and CA are device density and configuration dependant.

NOTE2. \overline{RESET} is Low enable command which will be used only for asynchronous reset so must be maintained HIGH during any function.

NOTE3. Bank addresses (BA) determine which bank is to be operated upon. For (E)MRS BA selects an (Extended) Mode Register.

NOTE4. "V" means "H or L (but a defined logic level)" and "X" means either "defined or undefined (like floating) logic level".

NOTE5. Burst reads or writes cannot be terminated or interrupted and Fixed/on-the-Fly BL will be defined by MRS.

NOTE6. The Power-Down Mode does not perform any refresh operation.

NOTE7. The state of ODT does not affect the states described in this table. The ODT function is not available during Self Refresh.

NOTE8. Self Refresh Exit is asynchronous.

NOTE9. VREF(Both VrefDQ and VrefCA) must be maintained during Self Refresh operation.

NOTE10. The No Operation command should be used in cases when the DDR3 SDRAM is in an idle or wait state. The purpose of the No Operation command (NOP) is to prevent the DDR3 SDRAM from registering any unwanted commands between operations. A No Operation command will not terminate a pervious operation that is still executing, such as a burst read or write cycle.

NOTE11. The Deselect command performs the same function as No Operation command.

NOTE12. Refer to the CKE Truth Table for more detail with CKE transition.

CKE Truth Table

Current State	CKE		Command (N) RAS, CAS, WE, CS	Action (N)	Notes
	Previous Cycle (N-1)	Current Cycle (N)			
Power-Down	L	L	X	Maintain Power-Down	
	L	H	DESELECT or NOP	Power-Down Exit	
Self-Refresh	L	L	X	Maintain Self-Refresh	
	L	H	DESELECT or NOP	Self-Refresh Exit	
Bank(s) Active	H	L	DESELECT or NOP	Active Power-Down Entry	
Reading	H	L	DESELECT or NOP	Power-Down Entry	
Writing	H	L	DESELECT or NOP	Power-Down Entry	
Precharging	H	L	DESELECT or NOP	Power-Down Entry	
Refreshing	H	L	DESELECT or NOP	Precharge Power-Down Entry	
All Banks Idle	H	L	DESELECT or NOP	Precharge Power-Down Entry	
	H	L	REFRESH	Self-Refresh	

NOTE 1 CKE (N) is the logic state of CKE at clock edge N; CKE (N-1) was the state of CKE at the previous clock edge.

NOTE 2 Current state is defined as the state of the DDR3 SDRAM immediately prior to clock edge N.

NOTE 3 COMMAND (N) is the command registered at clock edge N, and ACTION (N) is a result of COMMAND (N), ODT is not included here.

NOTE 4 All states and sequences not shown are illegal or reserved unless explicitly described elsewhere in this document.

NOTE 5 The state of ODT does not affect the states described in this table. The ODT function is not available during Self-Refresh.

NOTE 6 CKE must be registered with the same value on tCKEmin consecutive positive clock edges. CKE must remain at the valid input level the entire time it takes to achieve the tCKEmin clocks of registrations. Thus, after any CKE transition, CKE may not transition from its valid level during the time period of tIS + tCKEmin + tIH.

NOTE 7 DESELECT and NOP are defined in the Command Truth Table.

NOTE 8 On Self-Refresh Exit DESELECT or NOP commands must be issued on every clock edge occurring during the tXS period. Read or ODT commands may be issued only after tXSDLL is satisfied.

NOTE 9 Self-Refresh modes can only be entered from the All Banks Idle state.

NOTE 10 Must be a legal command as defined in the Command Truth Table.

NOTE 11 Valid commands for Power-Down Entry and Exit are NOP and DESELECT only.

NOTE 12 Valid commands for Self-Refresh Exit are NOP and DESELECT only.

NOTE 13 Self-Refresh cannot be entered during Read or Write operations.

NOTE 14 The Power-Down does not perform any refresh operations.

NOTE 15 "X" means "don't care" (including floating around VREF) in Self-Refresh and Power-Down. It also applies to Address pins.

NOTE 16 VREF (Both Vref_DQ and Vref_CA) must be maintained during Self-Refresh operation.

NOTE 17 If all banks are closed at the conclusion of the read, write or precharge command, then Precharge Power-Down is entered, otherwise Active Power-Down is entered.

NOTE 18 'Idle state' is defined as all banks are closed (tRP, tDAL, etc. satisfied), no data bursts are in progress, CKE is high, and all timings from previous operations are satisfied (tMRD, tMOD, tRFC, tZQinit, tZQoper, tZQCS, etc.)

On-Die Termination (ODT)

ODT (On-Die Termination) is a feature of the DDR3 SDRAM that allows the DRAM to turn on/off termination resistance for each DQ, DQS, \overline{DQS} , and DM for x4 and x8 configuration and TDQS, \overline{TDQS} for x8 configuration, when enabled via A11=1 in MR1) via the ODT control pin. The ODT feature is designed to improve signal integrity of the memory channel by allowing the DRAM controller to independently turn on/off termination resistance for any or all DRAM devices.

The ODT feature is turned off and not supported in Self-Refresh mode.

A simple functional representation of the DRAM ODT feature is shown as below.

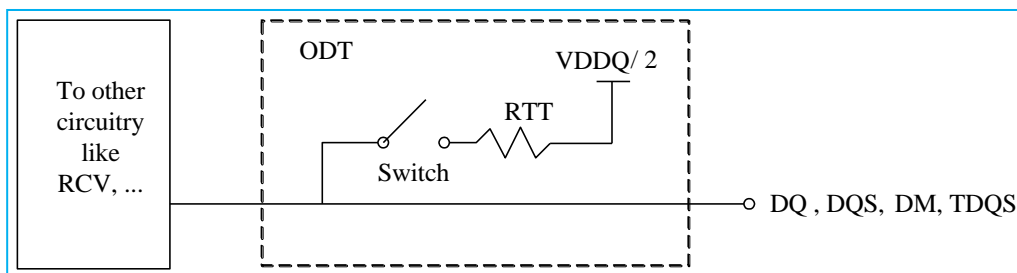

The switch is enabled by the internal ODT control logic, which uses the external ODT pin and other control information. The value of RTT is determined by the settings of Mode Register bits. The ODT pin will be ignored if the Mode Register MR1 and MR2 are programmed to disable ODT and in self-refresh mode.

ODT Mode Register and ODT Truth Table

The ODT Mode is enabled if either of MR1 {A2, A6, A9} or MR2 {A9, A10} are non-zero. In this case, the value of RTT is determined by the settings of those bits.

Application: Controller sends WR command together with ODT asserted.

One possible application: The rank that is being written to provides termination.

DRAM turns ON termination if it sees ODT asserted (except ODT is disabled by MR)

DRAM does not use any write or read command decode information.

Termination Truth Table

ODT pin	DRAM Termination State
0	OFF
1	ON, (OFF, if disabled by MR1 {A2, A6, A9} and MR2{A9, A10} in general)

Synchronous ODT Mode

Synchronous ODT mode is selected whenever the DLL is turned on and locked. Based on the power-down definition, these modes are:

Any bank active with CKE high

Refresh with CKE high

Idle mode with CKE high

Active power down mode (regardless of MR0 bit A12)

Precharge power down mode if DLL is enabled during precharge power down by MR0 bit A12

The direct ODT feature is not supported during DLL-off mode. The on-die termination resistors must be disabled by continuously registering the ODT pin low and/or by programming the RTT_Nom bits MR1{A9,A6,A2} to {0,0,0} via a mode register set command during DLL-off mode.

In synchronous ODT mode, RTT will be turned on ODTLon clock cycles after ODT is sampled high by a rising clock edge and turned off ODTLoff clock cycles after ODT is registered low by a rising clock edge. The ODT latency is tied to the write latency (WL) by: ODTLonn = WL - 2; ODTLoff = WL-2.

ODT Latency and Posted ODT

In synchronous ODT Mode, the Additive Latency (AL) programmed into the Mode Register (MR1) also applies to the ODT signal. The DRAM internal ODT signal is delayed for a number of clock cycles defined by the Additive Latency (AL) relative to the external ODT signal. ODTLon = CWL + AL - 2; ODTLoff = CWL + AL - 2. For details, refer to DDR3 SDRAM latency definitions.

ODT Latency

Symbol	Parameter	DDR3 SDRAM	Unit
ODTLon	ODT turn on Latency	WL - 2 = CWL + AL - 2	tCK
ODTLoff	ODT turn off Latency	WL - 2 = CWL + AL - 2	tCK

Timing Parameters

In synchronous ODT mode, the following timing parameters apply: ODTLon, ODTLoff, tAON min/max, AOF min/max.

Minimum RTT turn-on time (tAON min) is the point in time when the device leaves high impedance and ODT resistance begins to turn on. Maximum RTT turn-on time (tAON max) is the point in time when the ODT resistance is fully on. Both are measured from ODTLon.

Minimum RTT turn-off time (tAOF min) is the point in time when the device starts to turn off the ODT resistance. Maximum RTT turn off time (tAOF max) is the point in time when the on-die termination has reached high impedance. Both are measured from ODTLoff.

When ODT is asserted, it must remain high until ODTH4 is satisfied. If a Write command is registered by the SDRAM with ODT high, then ODT must remain high until ODTH4 (BL=4) or ODTH8 (BL=8) after the write command. ODTH4 and ODTH8 are measured from ODT registered high to ODT registered low or from the registration of a write command until ODT is registered low.

Synchronous ODT Timing Example for AL=3; CWL=5; ODTLon=AL+CWL-2=6; ODTLoff=AL+CWL-2=6

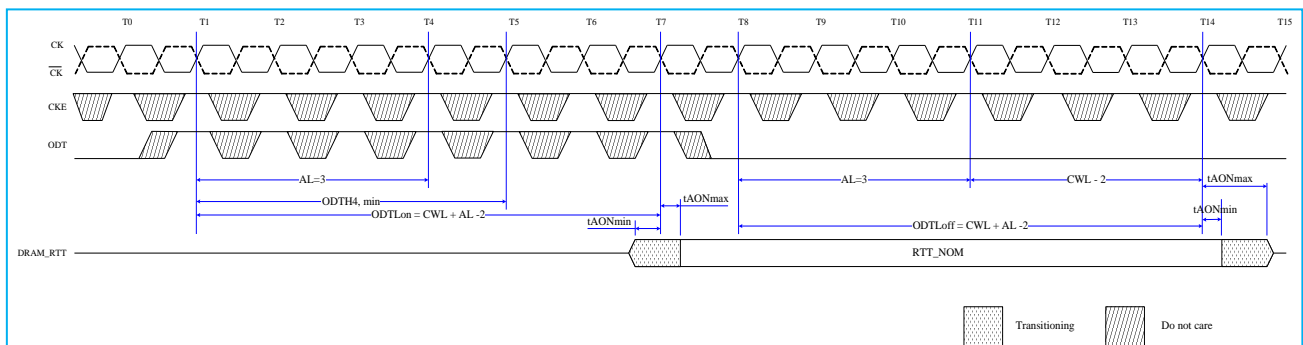

Synchronous ODT example with BL=4, WL=7

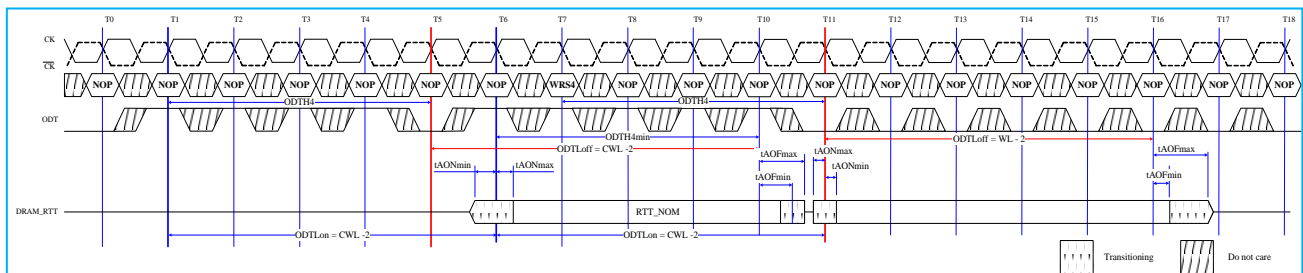

ODT must be held for at least ODTH4 after assertion (T1); ODT must be kept high ODTH4 (BL=4) or ODTH8 (BL=8) after Write command (T7). ODTH is measured from ODT first registered high to ODT first registered low, or from registration of Write command with ODT high to ODT registered low. Note that although ODTH4 is satisfied from ODT registered at T6 ODT must not go low before T11 as ODTH4 must also be satisfied from the registration of the Write command at T7.

ODT during Reads:

As the DDR3 SDRAM cannot terminate and drive at the same time, RTT must be disabled at least half a clock cycle before the read preamble by driving the ODT pin low appropriately. RTT may not be enabled until the end of the post-amble as shown in the following figure. DRAM turns on the termination when it stops driving which is determined by tHZ. If DRAM stops driving early (i.e. tHZ is early), then tAONmin time may apply. If DRAM stops driving late (i.e. tHZ is late), then DRAM complies with tAONmax timing. Note that ODT may be disabled earlier before the Read and enabled later after the Read than shown in this example.

ODT must be disabled externally during Reads by driving ODT low. (Example: CL=6; AL=CL-1=5; RL=AL+CL=11; CWL=5; ODTLon=CWL+AL-2=8; ODTLoff=CWL+AL-2=8)

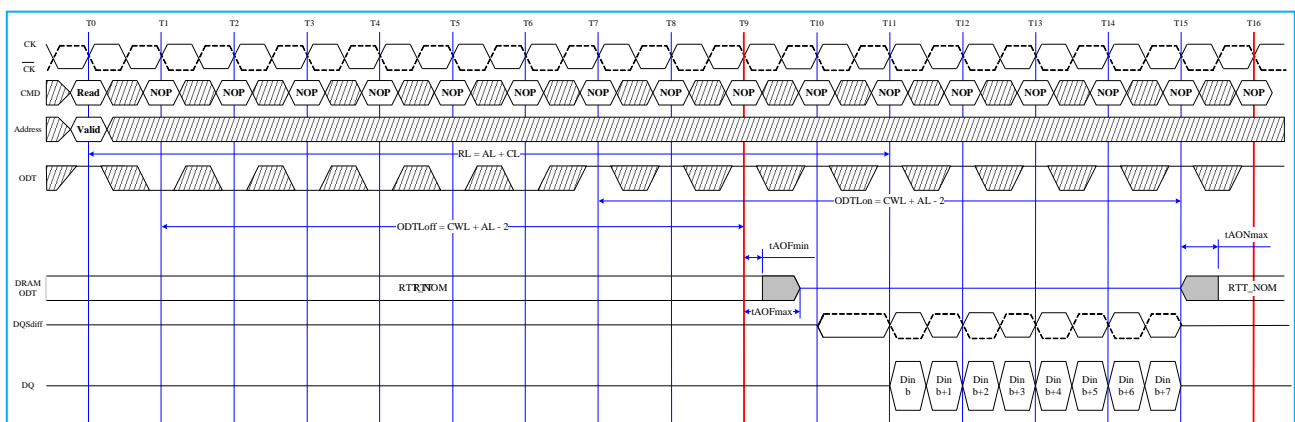

Dynamic ODT

In certain application cases and to further enhance signal integrity on the data bus, it is desirable that the termination strength of the DDR3 SDRAM can be changed without issuing an MRS command. This requirement is supported by the “Dynamic ODT” feature as described as follows:

Functional Description

The Dynamic ODT Mode is enabled if bit (A9) or (A10) of MR2 is set to ‘1’. The function is described as follows:

Two RTT values are available: RTT_Nom and RTT_WR.

The value for RTT_Nom is preselected via bits A[9,6,2] in MR1.

The value for RTT_WR is preselected via bits A[10,9] in MR2.

During operation without write commands, the termination is controlled as follows:

Nominal termination strength RTT_Nom is selected.

Termination on/off timing is controlled via ODT pin and latencies ODTLon and ODTLoff.

When a Write command (WR, WRA, WRS4, WRS8, WRAS4, WRAS8) is registered, and if Dynamic ODT is enabled, the termination is controlled as follows:

A latency ODTLcnw after the write command, termination strength RTT_WR is selected.

A latency ODTLcwn8 (for BL8, fixed by MRS or selected OTF) or ODTLcwn4 (for BC4, fixed by MRS or selected OTF) after the write command, termination strength RTT_Nom is selected.

Termination on/off timing is controlled via ODT pin and ODTLon, ODTLoff.

The following table shows latencies and timing parameters which are relevant for the on-die termination control in Dynamic ODT mode.

The dynamic ODT feature is not supported at DLL-off mode. User must use MRS command to set RTT_WR, MR2[A10,A9] = [0,0], to disable Dynamic ODT externally.

When ODT is asserted, it must remain high until ODTH4 is satisfied. If a Write command is registered by the SDRAM with ODT high, then ODT must remain high until ODTH4 (BL=4) or ODTH8 (BL=8) after the Write command. ODTH4 and ODTH8 are measured from ODT registered high to ODT registered low or from the registration of Write command until ODT is register low.

Latencies and timing parameters relevant for Dynamic ODT

Name and Description	Abbr.	Defined from	Defined to	Definition for all DDR3 speed bin	Unit
ODT turn-on Latency	ODTLon	registering external ODT signal high	turning termination on	ODTLon=WL-2	tCK
ODT turn-off Latency	ODTLoft	registering external ODT signal low	turning termination off	ODTLoft=WL-2	tCK
ODT Latency for changing from RTT_Nom to RTT_WR	ODTLcnw	registering external write command	change RTT strength from RTT_Nom to RTT_WR	ODTLcnw=WL-2	tCK
ODT Latency for change from RTT_WR to RTT_Nom (BL=4)	ODTLcnw4	registering external write command	change RTT strength from RTT_WR to RTT_Nom	ODTLcnw4=4+ODTLoft	tCK
ODT Latency for change from RTT_WR to RTT_Nom (BL=8)	ODTLcnw8	registering external write command	change RTT strength from RTT_WR to RTT_Nom	ODTLcnw8=6+ODTLoft	tCK(avg)
Minimum ODT high time after ODT assertion	ODTH4	registering ODT high	ODT registered low	ODTH4=4	tCK(avg)
Minimum ODT high time after Write (BL=4)	ODTH4	registering write with ODT high	ODT registered low	ODTH4=4	tCK(avg)
Minimum ODT high time after Write (BL=8)	ODTH8	registering write with ODT high	ODT register low	ODTH8=6	tCK(avg)
RTT change skew	tADC	ODTLcnw ODTLcnw	RTT valid	tADC(min)=0.3tCK(avg) tADC(max)=0.7tCK(avg)	tCK(avg)

Note: tAOF,nom and tADC,nom are 0.5tCK (effectively adding half a clock cycle to ODTLoft, ODTcnw, and ODTLcnw)

ODT Timing Diagrams

Dynamic ODT: Behavior with ODT being asserted before and after the write

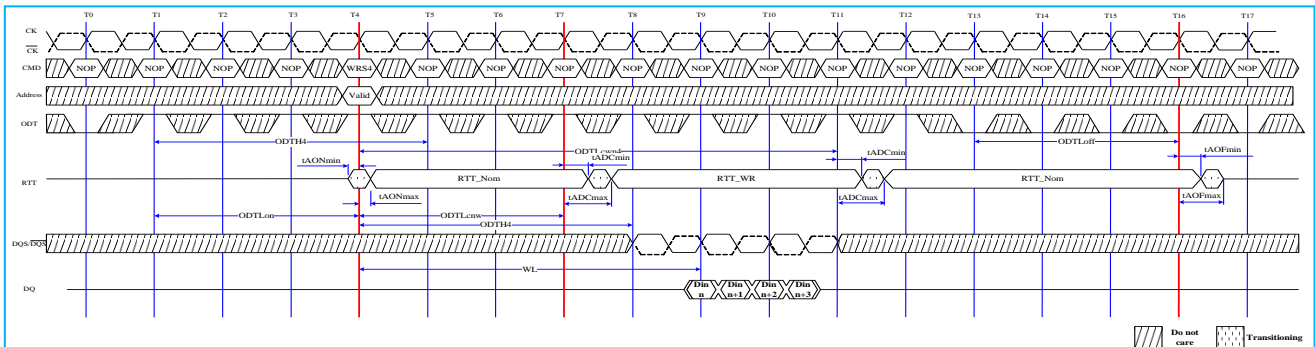

Note: Example for BC4 (via MRS or OTF), AL=0, CWL=5. ODTH4 applies to first registering ODT high and to the registration of the Write command. In this example ODTH4 would be satisfied if ODT went low at T8. (4 clocks after the Write command).

Dynamic ODT: Behavior without write command, AL=0, CWL=5

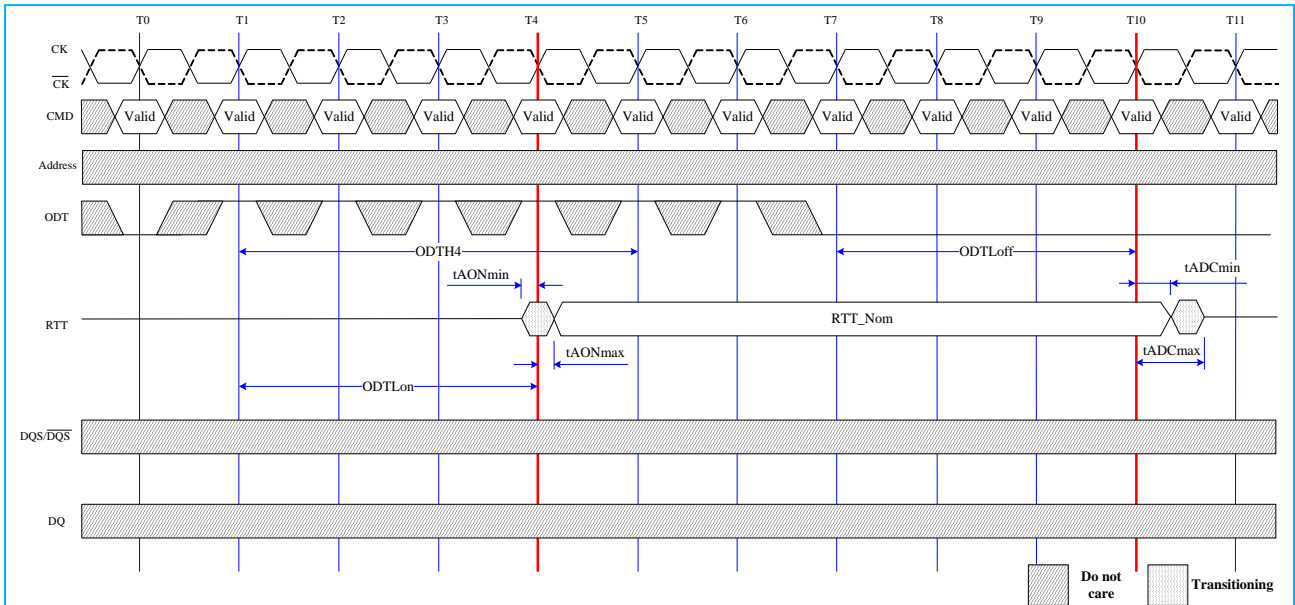

Note: $ODTH4$ is defined from ODT registered high to ODT registered low, so in this example $ODTH4$ is satisfied; ODT registered low at T5 would also be legal.

Dynamic ODT: Behavior with ODT pin being asserted together with write command for the duration of 6 clock cycles.

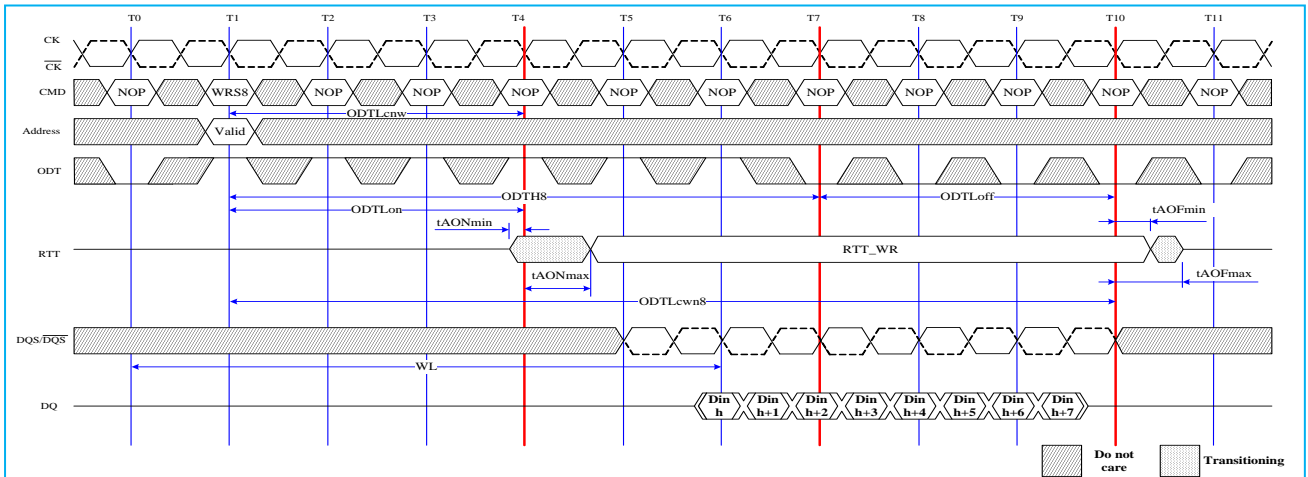

Note: Example for BL8 (via MRS or OTF), AL=0, CWL=5. In this example $ODTH8=6$ is exactly satisfied.

Dynamic ODT: Behavior with ODT pin being asserted together with write command for a duration of 6 clock cycles, example for BC4 (via MRS or OTF), AL=0, CWL=5.

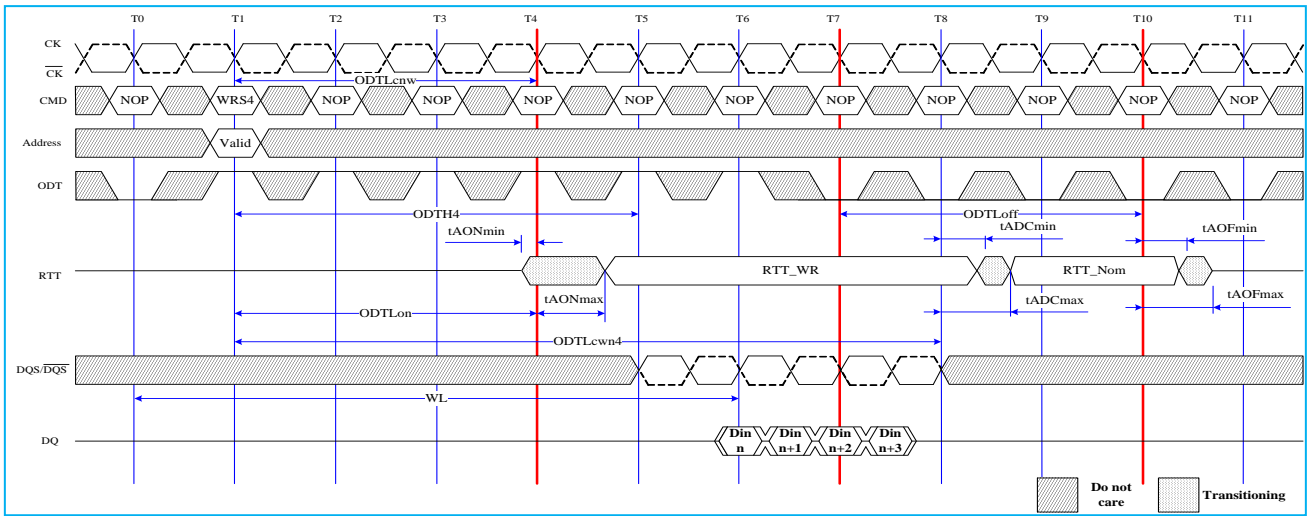

Dynamic ODT: Behavior with ODT pin being asserted together with write command for the duration of 4 clock cycles.

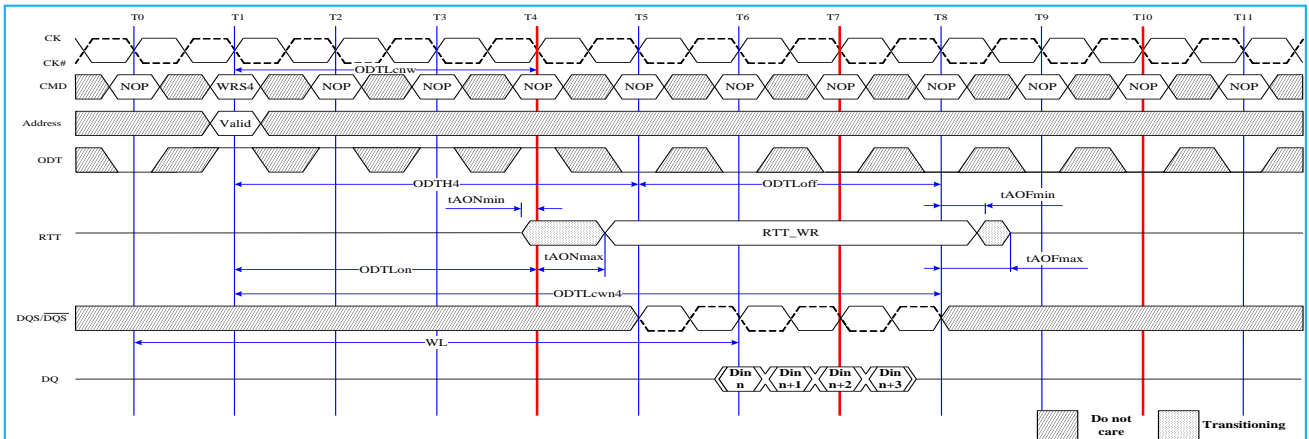

Asynchronous ODT Mode

Asynchronous ODT mode is selected when DRAM runs in DLLon mode, but DLL is temporarily disabled (i.e. frozen) in precharge power-down (by MR0 bit A12). Based on the power down mode definitions, this is currently Precharge power down mode if DLL is disabled during precharge power down by MR0 bit A12.

In asynchronous ODT timing mode, internal ODT command is NOT delayed by Additive Latency (AL) relative to the external ODT command.

In asynchronous ODT mode, the following timing parameters apply: tAONPD min/max, tAOFPD min/max.

Minimum RTT turn-on time (tAONPD min) is the point in time when the device termination circuit leaves high impedance state and ODT resistance begins to turn on. Maximum RTT turn on time (tAONPD max) is the point in time when the ODT resistance is fully on.

tAONPDmin and tAONPDmax are measured from ODT being sampled high.

Minimum RTT turn-off time (tAOFPDmin) is the point in time when the devices termination circuit starts to turn off the ODT resistance. Maximum ODT turn off time (tAOFPDmax) is the point in time when the on-die termination has reached high impedance. tAOFPDmin and tAOFPDmax are measured from ODT being sample low.

Asynchronous ODT Timings on DDR3 SDRAM with fast ODT transition: AL is ignored.

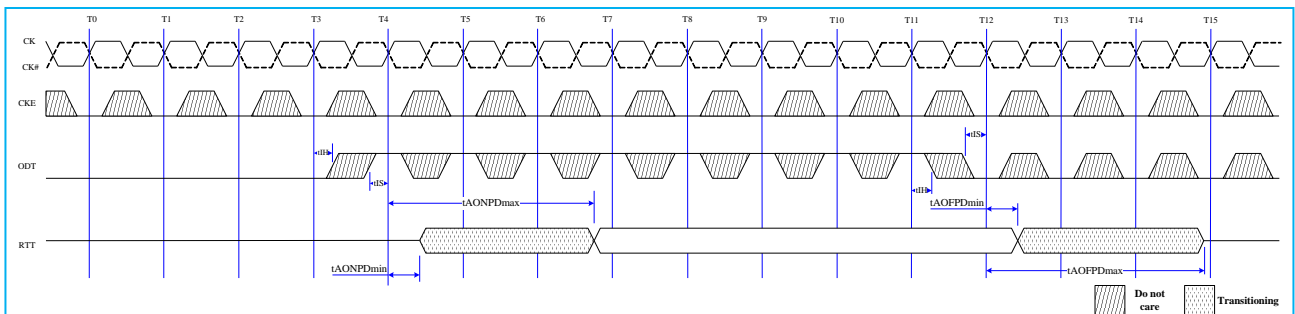

In Precharge Power Down, ODT receiver remains active, however no Read or Write command can be issued, as the respective ADD/CMD receivers may be disabled.

Asynchronous ODT Timing Parameters for all Speed Bins

Symbol	Description	min	max	Unit
tAONPD	Asynchronous RTT turn-on delay (Power-Down with DLL frozen)	1	9	ns
tAOFPD	Asynchronous RTT turn-off delay (Power-Down with DLL frozen)	1	9	ns

ODT timing parameters for Power Down (with DLL frozen) entry and exit transition period

Description	min	max
ODT to RTT turn-on delay	min{ ODTLon * tCK + tAONmin; tAONPDmin } min{ (WL - 2) * tCK + tAONmin; tAONPDmin }	max{ ODTLon * tCK + tAONmax; tAONPDmax } max{ (WL - 2) * tCK + tAONmax; tAONPFmax }
ODT to RTT turn-off delay	min{ ODTLoff * tCK + tAOFmin; tAOFPDmin } min{ (WL - 2) * tCK + tAOFmin; tAOFPDmin }	max{ ODTLoff * tCK + tAOFmax; tAOFPDmax } max{ (WL - 2) * tCK + tAOFmax; tAOFPDmax }
tANPD	WL-1	

Synchronous to Asynchronous ODT Mode Transition during Power-Down Entry

If DLL is selected to be frozen in Precharge Power Down Mode by the setting of bit A12 in MR0 to “0”, there is a transition period around power down entry, where the DDR3 SDRAM may show either synchronous or asynchronous ODT behavior.

The transition period is defined by the parameters t_{ANPD} and $t_{CPDED(min)}$. t_{ANPD} is equal to $(WL-1)$ and is counted backwards in time from the clock cycle where CKE is first registered low. $t_{CPDED(min)}$ starts with the clock cycle where CKE is first registered low. The transition period begins with the starting point of t_{ANPD} and terminates at the end point of $t_{CPDED(min)}$. If there is a Refresh command in progress while CKE goes low, then the transition period ends at the later one of $t_{RFC(min)}$ after the Refresh command and the end point of $t_{CPDED(min)}$. Please note that the actual starting point at t_{ANPD} is excluded from the transition period, and the actual end point at $t_{CPDED(min)}$ and $t_{RFC(min)}$, respectively, are included in the transition period.

ODT assertion during the transition period may result in an RTT changes as early as the smaller of $t_{AONPDmin}$ and $(ODTLon \cdot t_{ck} + t_{AONmin})$ and as late as the larger of $t_{AONPDmax}$ and $(ODTLon \cdot t_{CK} + t_{AONmax})$. ODT de-assertion during the transition period may result in an RTT change as early as the smaller of $t_{AOFPDmin}$ and $(ODTLoft \cdot t_{CK} + t_{AOFmin})$ and as late as the larger of $t_{AOFPDmax}$ and $(ODTLoft \cdot t_{CK} + t_{AOFmax})$. Note that, if AL has a large value, the range where RTT is uncertain becomes quite large. The following figure shows the three different cases: ODT_A, synchronous behavior before t_{ANPD} ; ODT_B has a state change during the transition period; ODT_C shows a state change after the transition period.

Synchronous to asynchronous transition during Precharge Power Down (with DLL frozen) entry (AL=0; CWL=5; $t_{ANPD}=WL-1=4$)

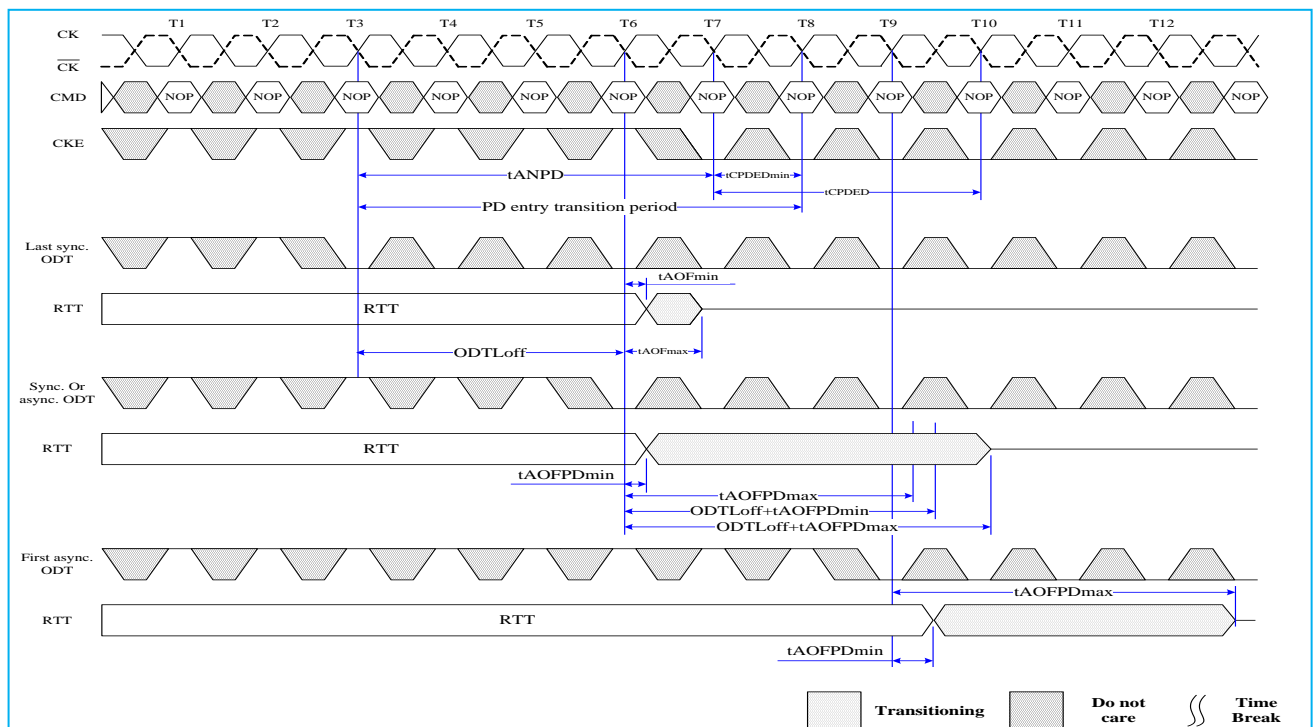

Asynchronous to Synchronous ODT Mode transition during Power-Down Exit

If DLL is selected to be frozen in Precharge Power Down Mode by the setting of bit A12 in MR0 to "0", there is also a transition period around power down exit, where either synchronous or asynchronous response to a change in ODT must be expected from the DDR3 SDRAM.

This transition period starts t_{ANPD} before CKE is first registered high, and ends t_{XPDLL} after CKE is first registered high. t_{ANPD} is equal to $(WL - 1)$ and is counted (backwards) from the clock cycle where CKE is first registered high.

ODT assertion during the transition period may result in an RTT change as early as the smaller of $t_{AONPDmin}$ and $(ODT_{Lon} * t_{CK} + t_{AONmin})$ and as late as the larger of $t_{AONPDmax}$ and $(ODT_{Lon} * t_{CK} + t_{AONmax})$. ODT de-assertion during the transition period may result in an RTT change as early as the smaller of $t_{AOFPDmin}$ and $(ODT_{Loff} * t_{CK} + t_{AOFmin})$ and as late as the larger of $t_{AOFPDmax}$ and $(ODT_{Loff} * t_{CK} + t_{AOFmax})$. Note that if AL has a large value, the range where RTT is uncertain becomes quite large. The following figure shows the three different cases: ODT_C, asynchronous response before t_{ANPD} ; ODT_B has a state change of ODT during the transition period; ODT_A shows a state change of ODT after the transition period with synchronous response.

Asynchronous to synchronous transition during Precharge Power Down (with DLL frozen) exit (CL=6; AL=CL-1; CWL=5; $t_{ANPD}=WL-1=9$)

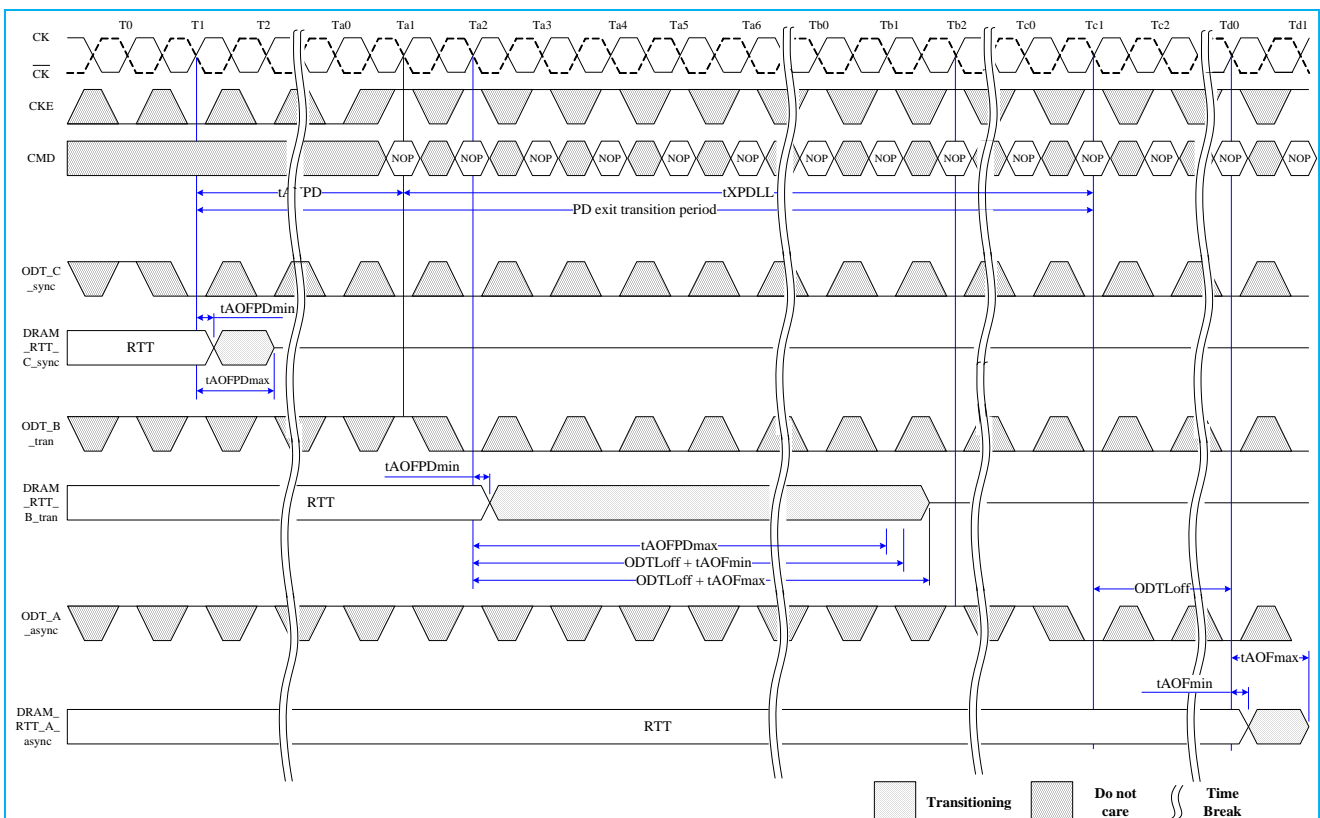

Asynchronous to Synchronous ODT Mode during short CKE high and short CKE low periods

If the total time in Precharge Power Down state or Idle state is very short, the transition periods for PD entry and PD exit may overlap. In this case, the response of the DDR3 SDRAMs RTT to a change in ODT state at the input may be synchronous or asynchronous from the state of the PD entry transition period to the end of the PD exit transition period (even if the entry ends later than the exit period).

If the total time in Idle state is very short, the transition periods for PD exit and PD entry may overlap. In this case, the response of the DDR3 SDRAMs RTT to a change in ODT state at the input may be synchronous or asynchronous from the state of the PD exit transition period to the end of the PD entry transition period. Note that in the following figure, it is assumed that there was no Refresh command in progress when Idle state was entered.

Transition period for short CKE cycles with entry and exit period overlapping

(AL=0; WL=5; tANPD=WL-1=4)

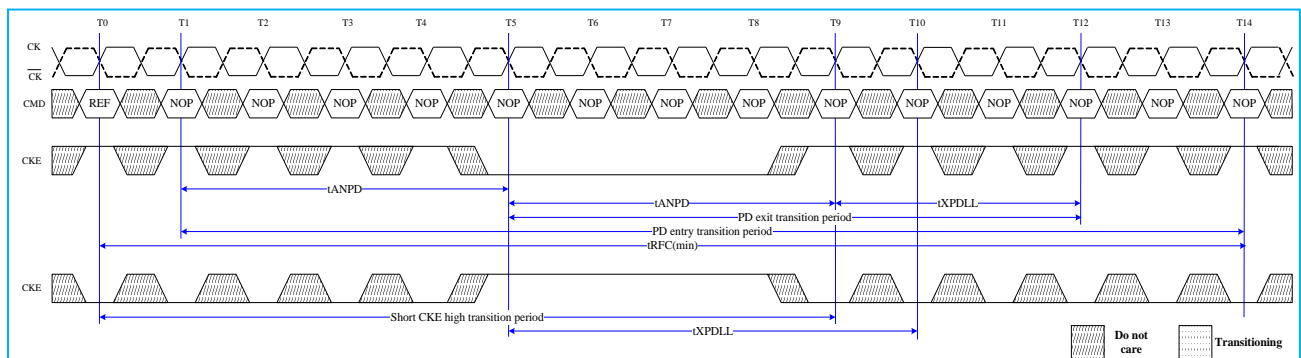

ZQ Calibration Commands

ZQ Calibration Description

ZQ Calibration command is used to calibrate DRAM Ron and ODT values. DDR3 SDRAM needs longer time to calibrate output driver and on-die termination circuits at initialization and relatively smaller time to perform periodic calibrations.

ZQCL command is used to perform the initial calibration during power-up initialization sequence. This command may be issued at any time by the controller depending on the system environment. ZQCL command triggers the calibration engine inside the DRAM and once calibration is achieved the calibrated values are transferred from calibration engine to DRAM IO which gets reflected as updated output driver and on-die termination values.

The first ZQCL command issued after reset is allowed a timing period of t_{ZQinit} to perform the full calibration and the transfer of values. All other ZQCL commands except the first ZQCL command issued after RESET is allowed a timing period of t_{ZQoper} .

ZQCS command is used to perform periodic calibrations to account for voltage and temperature variations. A shorter timing window is provided to perform the calibration and transfer of values as defined by timing parameter t_{ZQCS} .

No other activities should be performed on the DRAM channel by the controller for the duration of t_{ZQinit} , t_{ZQoper} , or t_{ZQCS} . The quiet time on the DRAM channel allows calibration of output driver and on-die termination values. Once DRAM calibration is achieved, the DRAM should disable ZQ current consumption path to reduce power.

All banks must be precharged and t_{RP} met before ZQCL or ZQCS commands are issued by the controller.

ZQ calibration commands can also be issued in parallel to DLL lock time when coming out of self refresh. Upon self-refresh exit, DDR3 SDRAM will not perform an IO calibration without an explicit ZQ calibration command. The earliest possible time for ZQ Calibration command (short or long) after self refresh exit is t_{XS} .

In systems that share the ZQ resistor between devices, the controller must not allow any overlap of t_{ZQoper} , t_{ZQinit} , or t_{ZQCS} between ranks.

ZQ Calibration Timing

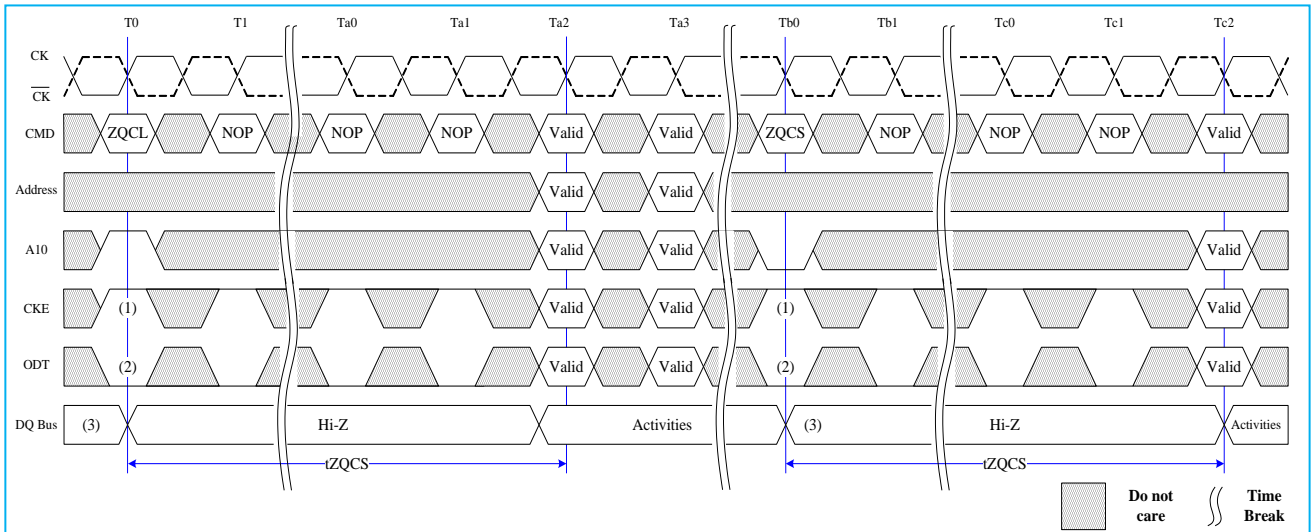

Note:

1. CKE must be continuously registered high during the calibration procedure.
2. On-die termination must be disabled via the ODT signal or MRS during the calibration procedure.
3. All devices connected to the DQ bus should be high impedance during the calibration procedure.

ZQ External Resistor Value, Tolerance, and Capacitive loading

In order to use the ZQ calibration function, a 240 ohm +/- 1% tolerance external resistor connected between the ZQ pin and ground. The single resistor can be used for each SDRAM or one resistor can be shared between two SDRAMs if the ZQ calibration timings for each SDRAM do not overlap. The total capacitive loading on the ZQ pin must be limited.

Absolute Maximum Ratings

Absolute Maximum DC Ratings

Symbol	Parameter	Rating	Units	Note
VDD	Voltage on VDD pin relative to Vss	-0.4 ~ 1.975	V	1,3
VDDQ	Voltage on VDDQ pin relative to Vss	-0.4 ~ 1.975	V	1,3
Vin, Vout	Voltage on any pin relative to Vss	-0.4 ~ 1.975	V	1
Tstg	Storage Temperature	-55 ~ 100	°C	1,2

Note:

1. Stresses greater than those listed under "Absolute Maximum Ratings" may cause permanent damage to the device. This is a stress rating only and functional operation of the device at these or any other conditions above those indicated in the operational sections of this specification is not implied. Exposure to absolute maximum rating conditions for extended periods may affect reliability.
2. Storage Temperature is the case surface temperature on the center/top side of the DRAM.
3. VDD and VDDQ must be within 300mV of each other at all times; and Vref must be not greater than 0.6VDDQ, when VDD and VDDQ are less than 500mV; Vref may be equal to or less than 300mV.

Temperature Range

Symbol	Parameter	Rating	Units	Notes
Toper	Normal Operating Temperature Range	0 to 85	°C	1,2
	Extended Temperature Range	85 to 95	°C	1,3

Note:

1. Operating Temperature Toper is the case surface temperature on the center/top side of the DRAM.
2. The Normal Temperature Range specifies the temperatures where all DRAM specification will be supported. During operation, the DRAM case temperature must be maintained between 0-85°C under all operating conditions.
3. Some applications require operation of the DRAM in the Extended Temperature Range between 85°C and 95°C case temperature. Full specifications are guaranteed in this range, but the following additional apply:
 - a) Refresh commands must be doubled in frequency, therefore, reducing the Refresh interval tREFI to 3.9us. It is also possible to specify a component with 1x refresh (tREFI to 7.8us) in the Extended Temperature Range.
 - b) If Self-Refresh operation is required in the Extended Temperature Range, then it is mandatory to either use the Manual Self-Refresh mode with Extended Temperature Range capability (MR2 A6=0 and MR2 A7=1) or enable the optional Auto Self-Refresh mode (MR2 A6=1 and MR2 A7=0).

AC & DC Operating Conditions
Recommended DC Operating Conditions

Symbol	Parameter	Rating			Unit	Note
		Min.	Typ.	Max.		
VDD	Supply Voltage	1.425	1.5	1.575	V	1,2
VDDQ	Supply Voltage for Output	1.425	1.5	1.575	V	1,2
VDD	Supply Voltage	1.28	1.35	1.45	V	1,2
VDDQ	Supply Voltage for Output	1.28	1.35	1.45	V	1,2

Note:

1. Under all conditions VDDQ must be less than or equal to VDD.
2. VDDQ tracks with VDD. AC parameters are measured with VDD and VDDQ tied together.

AC & DC Input Measurement Levels

AC and DC Logic Input Levels for Single-Ended Signals & Command and Address

Symbol	Parameter	DDR3-800/1066/1333/1600		Unit	Note
		Min.	Max.		
VIH.CA(DC100)	DC input logic high	Vref + 0.100	VDD	V	1
VIL.CA(DC100)	DC input logic low	VSS	Vref - 0.100	V	1
VIH.CA(AC175)	AC input logic high	Vref + 0.175	Note2	V	1,2
VIL.CA(AC175)	AC input logic low	Note2	Vref - 0.175	V	1,2
VIH.CA(AC150)	AC input logic high	Vref + 0.150	Note2	V	1,2
VIL.CA(AC150)	AC input logic low	Note2	Vref - 0.150	V	1,2
VREFCA(DC)	Reference Voltage for ADD, CMD inputs	0.49 * VDD	0.51 * VDD	V	3,4

Note:

1. For input only pins except RESET. Vref=VrefCA(DC)
2. See "Overshoot and Undershoot Specifications"
3. The ac peak noise on Vref may not allow Vref to deviate from Vref(DC) by more than +/- 0.1% VDD.
4. For reference: approx. VDD/2 +/- 15mV.
5. To allow VREFCA margining, all DRAM Command and Address Input Buffers MUST use external VREF (provided by system) as the input for their VREFCA pins. All VIH/L input level MUST be compared with the external VREF level at the 1st stage of the Command and Address input buffer

AC and DC Logic Input Levels for Single-Ended Signals & DQ and DM

Symbol	Parameter	DDR3-800/1066		DDR3-1333/1600		Unit	Note
		Min.	Max.	Min.	Max.		
VIH.DQ(DC100)	DC input logic high	Vref + 0.100	VDD	Vref + 0.100	VDD	V	1
VIL.DQ(DC100)	DC input logic low	VSS	Vref - 0.100	VSS	Vref - 0.100	V	1
VIH.DQ(AC175)	AC input logic high	Vref + 0.175	Note2	Vref + 0.150	Note2	V	1,2,5
VIL.DQ(AC175)	AC input logic low	Note2	Vref - 0.175	Note2	Vref - 0.150	V	1,2,5
VIH.DQ(AC150)	AC input logic high	Vref + 0.150	Note2	Vref + 0.150	Note2	V	1,2,5
VIL.DQ(AC150)	AC input logic low	Note2	Vref - 0.150	Note2	Vref - 0.150	V	1,2,5
VREFDQ(DC)	Reference Voltage for DQ, DM inputs	0.49 * VDD	0.51 * VDD	0.49 * VDD	0.51 * VDD	V	3,4
VREFDQ_t(DC)	Reference Voltage for trained DQ, DM inputs	0.45 * VDD	0.55 * VDD	0.45 * VDD	0.55 * VDD	V	3,4 6,7

Note:

1. For input only pins except $\overline{\text{RESET}}$. Vref = VrefDQ(DC)
2. See "Overshoot and Undershoot Specifications"
3. The ac peak noise on Vref may not allow Vref to deviate from Vref(DC) by more than $\pm 0.1\%$ VDD.
4. For reference: approx. $VDD/2 \pm 15\text{mV}$.
5. Single-ended swing requirement for $\text{DQS-}\overline{\text{DQS}}$, is 350mV (peak to peak). Differential swing requirement for $\text{DQS-}\overline{\text{DQS}}$, is 700mV (peak to peak)
6. VRefDQ training is performed only during system boot. Once the training is completed and an optimal VRefDQ_t(DC) voltage level is identified, the optimal VRefDQ_t(DC) voltage level will be used during system runtime. During VRefDQ training, VRefDQ is swept from 40% of VDD to 60% of VDD to find the optimal VRefDQ_t(DC) voltage level; and once the optimal VRefDQ_t(DC) is set, it must stay within +/- 1% of its set value as well as not be less than 45% of VDD or exceed 55% of VDD. $\text{VIH.DQ(AC)min/VIL.DQ(AC)max} = \text{Optimal VRefDQ}_t(\text{DC}) \pm \text{AC Level}$, where "AC Level" is the actual AC voltage level per DDR3 speed bins as specified in JESD79-3 specification. After VRefDQ training is completed and the optimal VRefDQ_t(DC) is set, the Memory Controller provides the DRAM device a valid write window. Through DQS placement optimization and VRefDQ centering, the valid write window is optimized for both input voltage margin and tDS+tDH window for the DRAM receiver. The DRAM device supports the use of the above techniques to optimize the write timing and voltage margin, as long as the technique does not create any DIMM failures due to DRAM input voltage and/or timing spec violations as defined in JESD79-3 specification.
7. To allow VREFDQ margining, all DRAM Data Input Buffers MUST use external VREF (provided by system) as the input for their VREFDQ pins. All VIH/L input level MUST be compared with the external VREF level at the 1st stage of the Data input buffer.

AC and DC Output Measurement Levels

Single Ended AC and DC Output Levels

Symbol	Parameter	Value	Unit	Notes
VOH(DC)	DC output high measurement level (for IV curve linearity)	0.8xVDDQ	V	
VOM(DC)	DC output mid measurement level (for IV curve linearity)	0.5xVDDQ	V	
VOL(DC)	DC output low measurement level (fro IV curve linearity)	0.2xVDDQ	V	
VOH(AC)	AC output high measurement level (for output SR)	VTT+0.1xVDDQ	V	1
VOL(AC)	AC output low measurement level (for output SR)	VTT-0.1xVDDQ	V	1

Note:

1. The swing of $\pm 0.1 \times VDDQ$ is based on approximately 50% of the static single ended output high or low swing with a driver impedance of 40 Ω and an effective test load of 25 Ω to $VTT = VDDQ/2$.

Differential AC and DC Output Levels

Symbol	Parameter	DDR3	Unit	Notes
VOHdiff(AC)	AC differential output high measurement level (for output SR)	+0.2 x VDDQ	V	1
VOLdiff(AC)	AC differential output low measurement level (for output SR)	-0.2 x VDDQ	V	1

Note:

1. The swing of $\pm 0.2 \times VDDQ$ is based on approximately 50% of the static differential output high or low swing with a driver impedance of 40 Ω and an effective test load of 25 Ω to $VTT=VDDQ/2$ at each of the differential outputs.

ODT DC Electrical Characteristics, assuming $R_{ZQ} = 240\text{ohms} \pm 1\%$ entire operating temperature range; after proper ZQ calibration

MR1 A9, A6, A2	RTT	Resistor	Vout	min	nom	max	Unit	Notes
0, 1, 0	120Ω	RTT _{120Pd240}	VOLdc = 0.2 x VDDQ	0.6	1	1.1	R _{ZQ}	1,2,3,4
			0.5 x VDDQ	0.9	1	1.1	R _{ZQ}	1,2,3,4
			VOHdc = 0.8 x VDDQ	0.9	1	1.4	R _{ZQ}	1,2,3,4
		RTT _{120Pu240}	VOLdc = 0.2 x VDDQ	0.9	1	1.4	R _{ZQ}	1,2,3,4
			0.5 x VDDQ	0.9	1	1.1	R _{ZQ}	1,2,3,4
			VOHdc = 0.8 x VDDQ	0.6	1	1.1	R _{ZQ}	1,2,3,4
RTT ₁₂₀	VIL(ac) to VIH(ac)	0.9	1	1.6	R _{ZQ} /2	1,2,5		
0, 0, 1	60Ω	RTT _{60Pd120}	VOLdc = 0.2 x VDDQ	0.6	1	1.1	R _{ZQ} /2	1,2,3,4
			0.5 x VDDQ	0.9	1	1.1	R _{ZQ} /2	1,2,3,4
			VOHdc = 0.8 x VDDQ	0.9	1	1.4	R _{ZQ} /2	1,2,3,4
		RTT _{60Pu120}	VOLdc = 0.2 x VDDQ	0.9	1	1.4	R _{ZQ} /2	1,2,3,4
			0.5 x VDDQ	0.9	1	1.1	R _{ZQ} /2	1,2,3,4
			VOHdc = 0.8 x VDDQ	0.6	1	1.1	R _{ZQ} /2	1,2,3,4
RTT ₆₀	VIL(ac) to VIH(ac)	0.9	1	1.6	R _{ZQ} /4	1,2,5		
0, 1, 1	40Ω	RTT _{40Pd80}	VOLdc = 0.2 x VDDQ	0.6	1	1.1	R _{ZQ} /3	1,2,3,4
			0.5 x VDDQ	0.9	1	1.1	R _{ZQ} /3	1,2,3,4
			VOHdc = 0.8 x VDDQ	0.9	1	1.4	R _{ZQ} /3	1,2,3,4
		RTT _{40Pu80}	VOLdc = 0.2 x VDDQ	0.9	1	1.4	R _{ZQ} /3	1,2,3,4
			0.5 x VDDQ	0.9	1	1.1	R _{ZQ} /3	1,2,3,4
			VOHdc = 0.8 x VDDQ	0.6	1	1.1	R _{ZQ} /3	1,2,3,4
RTT ₄₀	VIL(ac) to VIH(ac)	0.9	1	1.6	R _{ZQ} /6	1,2,5		
1, 0, 1	30Ω	RTT _{30Pd60}	VOLdc = 0.2 x VDDQ	0.6	1	1.1	R _{ZQ} /4	1,2,3,4
			0.5 x VDDQ	0.9	1	1.1	R _{ZQ} /4	1,2,3,4
			VOHdc = 0.8 x VDDQ	0.9	1	1.4	R _{ZQ} /4	1,2,3,4
		RTT _{30Pu60}	VOLdc = 0.2 x VDDQ	0.9	1	1.4	R _{ZQ} /4	1,2,3,4
			0.5 x VDDQ	0.9	1	1.1	R _{ZQ} /4	1,2,3,4
			VOHdc = 0.8 x VDDQ	0.6	1	1.1	R _{ZQ} /4	1,2,3,4
RTT ₃₀	VIL(ac) to VIH(ac)	0.9	1	1.6	R _{ZQ} /8	1,2,5		
1, 0, 0	20Ω	RTT _{20Pd40}	VOLdc = 0.2 x VDDQ	0.6	1	1.1	R _{ZQ} /6	1,2,3,4
			0.5 x VDDQ	0.9	1	1.1	R _{ZQ} /6	1,2,3,4
			VOHdc = 0.8 x VDDQ	0.9	1	1.4	R _{ZQ} /6	1,2,3,4
		RTT _{20Pu40}	VOLdc = 0.2 x VDDQ	0.9	1	1.4	R _{ZQ} /6	1,2,3,4
			0.5 x VDDQ	0.9	1	1.1	R _{ZQ} /6	1,2,3,4
			VOHdc = 0.8 x VDDQ	0.6	1	1.1	R _{ZQ} /6	1,2,3,4
RTT ₂₀	VIL(ac) to VIH(ac)	0.9	1	1.6	R _{ZQ} /12	1,2,5		
Deviation of VM w.r.t. VDDQ/2, DVm				-5		+5	%	1,2,5,6

Note:

- The tolerance limits are specified after calibration with stable voltage and temperature. For the behavior of the tolerance limits if temperature or voltage changes after calibration, see following section on voltage and temperature sensitivity.
- The tolerance limits are specified under the condition that VDDQ = VDD and that VSSQ = VSS.
- Pull-down and pull-up ODT resistors are recommended to be calibrated at 0.5 x VDDQ. Other calibration may be used to achieve the linearity spec shown above.
- Not a specification requirement, but a design guide line.
- Measurement definition for RTT:
Apply VIH(ac) to pin under test and measure current / (VIH(ac)), then apply VIL(ac) to pin under test and measure current / (VIL(ac)) respectively.
 $RTT = [VIH(ac) - VIL(ac)] / [(VIH(ac)) - I(VIL(ac))]$
- Measurement definition for VM and DV_M:
Measure voltage (VM) at test pin (midpoint) with no lead:
 $\Delta V_M = [2V_M / VDDQ - 1] \times 100$

ODT Temperature and Voltage sensitivity

If temperature and/or voltage after calibration, the tolerance limits widen according to the following table.

Delta T = T - T(@calibration); Delta V = VDDQ - VDDQ(@calibration); VDD = VDDQ

ODT Sensitivity Definition

	min	max	Unit
RTT	$0.9 - dRTTdT * \Delta T - dRTTdV * \Delta V$	$1.6 + dRTTdT * \Delta T + dRTTdV * \Delta V$	RZQ/2,4,6,8,12

ODT Voltage and Temperature Sensitivity

	min	max	Unit
dRTTdT	0	1.5	%/°C
dRTTdV	0	0.15	%/mV

Note: These parameters may not be subject to production test. They are verified by design and characterization.

Test Load for ODT Timings

Different than for timing measurements, the reference load for ODT timings is defined in the following figure.

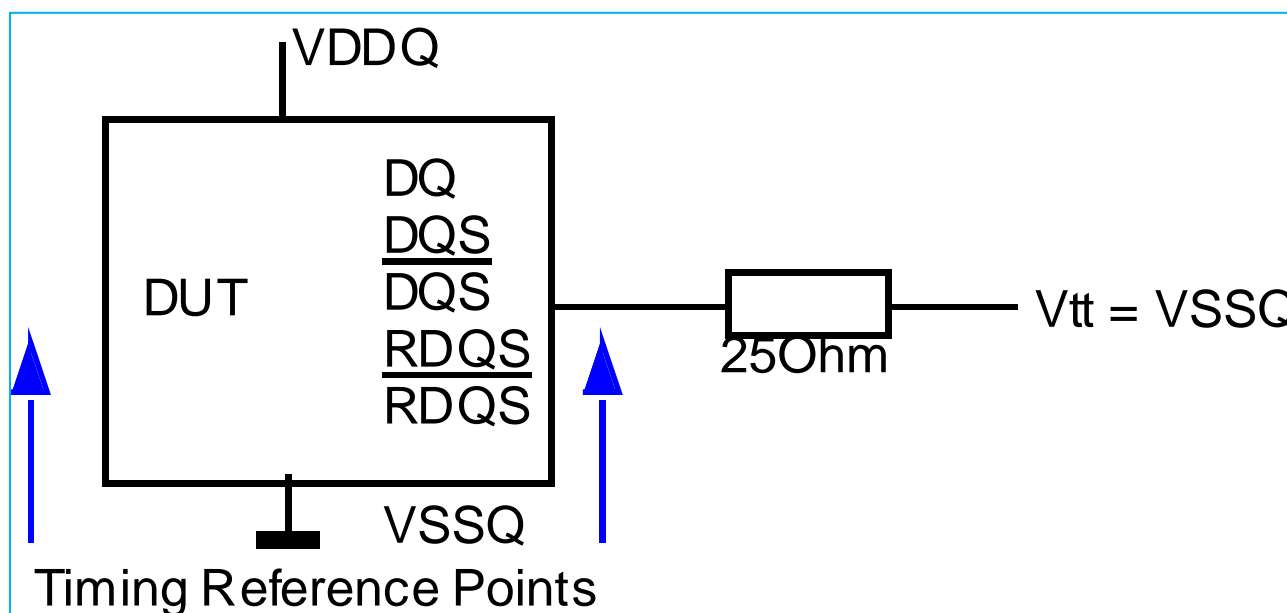

ODT Timing Definitions

Definitions for t_{AON}, t_{AONPD}, t_{AOFF}, t_{AOFFPD}, and t_{ADC} are provided in the following table and subsequent figures.

Symbol	Begin Point Definition	End Point Definition
t _{AON}	Rising edge of CK - CK defined by the end point of ODTLon	Extrapolated point at VSSQ
t _{AONPD}	Rising edge of CK - CK with ODT being first registered high	Extrapolated point at VSSQ
t _{AOFF}	Rising edge of CK - CK defined by the end point of ODTLoff	End point: Extrapolated point at VR _{TT} _Nom
t _{AOFFPD}	Rising edge of CK - CK with ODT being first registered low	End point: Extrapolated point at VR _{TT} _Nom
t _{ADC}	Rising edge of CK - CK defined by the end point of ODTLcwn, ODTLcwn4, or ODTLcwn8	End point: Extrapolated point at VR _{TT} _Wr and VR _{TT} _Nom respectively

Reference Settings for ODT Timing Measurements

Measured Parameter	RTT_Nom Setting	RTT_Wr Setting	VSW1[V]	VSW2[V]	Note
tAON	RZQ/4	NA	0.05	0.10	
	RZQ/12	NA	0.10	0.20	
tAONPD	RZQ/4	NA	0.05	0.10	
	RZQ/12	NA	0.10	0.20	
tAOF	RZQ/4	NA	0.05	0.10	
	RZQ/12	NA	0.10	0.20	
tAOFPD	RZQ/4	NA	0.05	0.10	
	RZQ/12	NA	0.10	0.20	
tADC	RZQ/12	RZQ/2	0.20	0.30	

Input / Output Capacitance

Symbol	Parameter	DDR3-800		DDR3-1066		DDR3-1333		DDR3-1600		Units	Notes
		Min.	Max	Min.	Max	Min.	Max	Min.	Max		
C _{IO}	Input/output capacitance (DQ, DM, DQS, \overline{DQS} , TDQS, \overline{TDQS})	1.50	3.00	1.50	3.00	1.50	2.50	1.50	2.30	pF	1,2,3
C _{CK}	Input capacitance, CK and \overline{CK}	0.80	1.60	0.80	1.60	0.80	1.40	0.80	1.40	pF	2,3
C _{DCK}	Input capacitance delta, CK and \overline{CK}	0.00	0.15	0.00	0.15	0.00	0.15	0.00	0.15	pF	2,3,4
C _{DDQS}	Input/output capacitance delta, DQS and \overline{DQS}	0.00	0.20	0.00	0.20	0.00	0.15	0.00	0.15	pF	2,3,5
C _I	Input capacitance, CTRL, ADD, CMD input-only pins	0.75	1.40	0.75	1.35	0.75	1.30	0.75	1.30	pF	2,3,7,8
C _{DI_CTRL}	Input capacitance delta, all CTRL input-only pins	-0.50	0.30	-0.50	0.30	-0.40	0.20	-0.40	0.20	pF	2,3,7,8
C _{DI_ADD_CMD}	Input capacitance delta, all ADD/CMD input-only pins	-0.50	0.50	-0.50	0.50	-0.40	0.40	-0.40	0.40	pF	2,3,9,10
C _{DIO}	Input/output capacitance delta, DQ, DM, DQS, \overline{DQS} , TDQS, \overline{TDQS}	-0.50	0.30	-0.50	0.30	-0.50	0.30	-0.50	0.30	pF	2,3,11
C _{ZQ}	Input/output capacitance of ZQ pin	-	3.00	-	3.00	-	3.00	-	3.00	pF	2,3,12

1. Although the DM, TDQS and \overline{TDQS} pins have different functions, the loading matches DQ and DQS
2. This parameter is not subject to production test. It is verified by design and characterization. VDD=VDDQ=1.5V, VBIAS=VDD/2 and on-
3. This parameter applies to monolithic devices only; stacked/dual-die devices are not covered here
4. Absolute value of CCK-CCK
5. Absolute value of CIO(DQS)-CIO(DQS)
6. C_I applies to ODT, \overline{CS} , CKE, A0-A13, BA0-BA2, \overline{RAS} , \overline{CAS} , \overline{WE}
7. C_{DI_CTRL} applies to ODT, \overline{CS} and CKE
8. $C_{DI_CTRL}=C_I(CTRL)-0.5*(C_I(CLK)+C_I(\overline{CLK}))$
9. C_{DI_ADD_CMD} applies to A0-A13, BA0-BA2, \overline{RAS} , \overline{CAS} and \overline{WE}
10. $C_{DI_ADD_CMD}=C_I(ADD_CMD) - 0.5*(C_I(CLK)+C_I(\overline{CLK}))$
11. $C_{DIO}=C_{IO}(DQ,DM) - 0.5*(C_{IO}(DQS)+C_{IO}(\overline{DQS}))$
12. Maximum external load capacitance on ZQ pin: 5 pF.

IDD Specifications and Measurement Conditions

Symbol	Parameter/Condition	DDR3-800MHz			DDR3-1066MHz			DDR3-1333MHz			DDR3-1600MHz			Unit
		X4	X8	X16	X4	X8	X16	X4	X8	X16	X4	X8	X16	
IDD0	Operating Current 0 -> One Bank Activate -> Precharge	70	70	80	75	75	90	85	85	100	95	95	110	mA
IDD1	Operating Current 1 -> One Bank Activate -> Read -> Precharge	90	90	120	95	95	125	100	100	130	105	105	135	mA
IDD2P0	Precharge Power-Down Current Slow Exit - MR0 bit A12 = 0	12	12	12	12	12	12	12	12	12	12	12	12	mA
IDD2P1	Precharge Power-Down Current Fast Exit - MR0 bit A12 = 1	20	20	25	25	25	30	30	30	35	35	35	40	mA
IDD2Q	Precharge Quiet Standby Current	25	25	25	30	30	30	35	35	35	40	40	40	mA
IDD2N	Precharge Standby Current	30	30	30	35	35	35	40	40	40	45	45	45	mA
IDD3P	Active Power-Down Current Always Fast Exit	25	25	30	30	30	35	35	35	40	40	40	45	mA
IDD3N	Active Standby Current	30	30	30	35	35	35	40	40	40	45	45	45	mA
IDD4R	Operating Current Burst Read	120	120	180	140	140	210	160	160	240	180	180	270	mA
IDD4W	Operating Current Burst Write	125	125	190	145	145	210	165	165	255	185	185	280	mA
IDD5B	Burst Refresh Current	180	180	180	190	190	190	200	200	200	210	210	210	mA
IDD6	Self-Refresh Current Normal Temperature Range (0-85°C)	12	12	12	12	12	12	12	12	12	12	12	12	mA
IDD7	All Bank Interleave Read Current	280	280	300	310	310	330	330	330	370	370	370	400	mA

Symbol	Parameter/Condition	DDR3-800MHz			DDR3-1066MHz			DDR3-1333MHz			DDR3-1600MHz			Unit
		X4	X8	X16	X4	X8	X16	X4	X8	X16	X4	X8	X16	
IDD0	Operating Current 0 -> One Bank Activate -> Precharge	65	65	73	69	69	83	78	78	92	87	87	100	mA
IDD1	Operating Current 1 -> One Bank Activate -> Read -> Precharge	83	83	110	87	87	115	92	92	120	96	96	124	mA
IDD2P0	Precharge Power-Down Current Slow Exit - MR0 bit A12 = 0	11	11	11	11	11	11	11	11	11	11	11	11	mA
IDD2P1	Precharge Power-Down Current Fast Exit - MR0 bit A12 = 1	18.5	18.5	23	23	23	27.5	27.5	27.5	32	32	32	36.5	mA
IDD2Q	Precharge Quiet Standby Current	23	23	23	27.5	27.5	27.5	32	32	32	36.5	36.5	36.5	mA
IDD2N	Precharge Standby Current	27.5	27.5	27.5	32	32	32	36.5	36.5	36.5	41.5	41.5	41.5	mA
IDD3P	Active Power-Down Current Always Fast Exit	23	23	27.5	27.5	27.5	32	32	32	36.5	36.5	36.5	41.5	mA
IDD3N	Active Standby Current	27.5	27.5	27.5	32	32	32	36.5	36.5	36.5	41.5	41.5	41.5	mA
IDD4R	Operating Current Burst Read	110	110	165	130	130	190	147	147	220	165	165	247.5	mA
IDD4W	Operating Current Burst Write	115	115	175	130	130	190	150	150	235	170	170	255	mA
IDD5B	Burst Refresh Current	165	165	165	175	175	175	185	185	185	190	190	190	mA
IDD6	Self-Refresh Current Normal Temperature Range (0-85°C)	11	11	11	11	11	11	11	11	11	11	11	11	mA
IDD7	All Bank Interleave Read Current	250	250	270	280	280	300	300	300	340	330	330	370	mA

IDD Measurement Conditions

Symbol	Parameter/Condition
IDD0	Operating Current - One bank Active - Precharge current CKE: High; External clock: On; tCK, tRC, tRAS: see table in the next page; CS: High between ACT and PRE; Command Inputs: SWITCHING ¹ (except for ACT and PRE); Row, Column Address, Data I/O: SWITCHING1 (A10 Low permanently); Bank Address: fixed (Bank 0); Output Buffer: off ² ; ODT: disabled ³ ; Active Banks: one (ACT-PRE loop); Idle Banks: all other; Pattern example: A0 D DD DD DD DD DD DD D P0 ⁴ (DDR3-800: tRAS=37.5ns)
IDD1	Operating One bank Active-Read-Precharge Current CKE: High; External clock: On; tCK, tRC, tRAS, tRCD, CL, AL: see table in the next page; CS: High between ACT, RD, and PRE; Command Inputs: SWITCHING ¹ (except ACT, RD, and PRE Commands); Row, Column Address: SWITCHING1 (A10 Low permanently); Bank Address: fixed (Bank 0); Data I/O: switching every clock (RD Data stable during one Clock cycle); floating when no burst activity; Output Buffer: Off ² ; ODT: disabled ³ ; Burst Length: BL8 ⁵ ; Active Banks: one (ACT-RD-PRE loop); Idle Banks: all other; Pattern example: A0 D DD D R0 DD DD DD DD D P0 ⁴ (DDR3-800-5-5-5: tRCD=12.5ns).
IDD2N	Precharge Standby Current CKE=High; External Clock=On; tCK: see table in the next page; CS: High; Command Inputs, Row, Column, Bank Address, Data I/O: SWITCHING ¹ ; Output Buffer: Off ² ; ODT: disabled ³ ; Active / Idle Banks: none / all.
IDD2P(0)	Precharge Power-Down Current - (Slow Exit) CKE=Low; External Clock=On; tCK: see table in the next page; CS: Stable; Command Inputs: Stable; Row, Column / Bank Address: Stable; Data I/O: floating; Output Buffer: Off ² ; ODT: disabled ³ ; Active / Idle Banks: none / all. Precharge Power Down Mode: Slow Exit ⁶ (RD and ODT must satisfy tXPDLL - AL)
IDD2P(1)	Precharge Power-Down Current - (Fast Exit) CKE=Low; External Clock=On; tCK: see table in the next page; CS: Stable; Command Inputs, Row, Column, Bank Address: Stable; Data I/O: floating; Output Buffer: Off ² ; ODT: disabled ³ ; Active / Idle Banks: none / all. Precharge Power Down Mode: Fast Exit ⁶ (any valid Command after tXP) ⁷
IDD2Q	Precharge Quiet Standby Current CKE=High; External Clock=On; tCK: see table in the next page; CS=High; Command Inputs, Row, Column, Bank Address: Stable; Data I/O: floating; Output Buffer: Off ² ; ODT: disabled ³ ; Active / Idle Banks: none / all.
IDD3N	Active Standby Current CKE=High; External Clock=On; tCK: see table in the next page; CS=High; Command Inputs, Row, Column, Bank Address, Data I/O: SWITCHING ¹ ; Output Buffer: Off ² ; ODT: disabled ³ ; Active / Idle Banks: All / none.
IDD3P	Active Power-Down Current CKE=Low; External Clock=On; tCK: see table in the next page; CS, Command Inputs, Row, Column, Bank Address: Stable; Data I/O: floating; Output Buffer: Off ² ; ODT: disabled ³ ; Active / Idle Banks: All / none.
IDD4R	Operating Burst Read Current CKE=High; External Clock=On; tCK, CL: see table in the next page; AL: 0; CS: High between valid Commands; Command Inputs: SWITCHING ¹ (except RD Commands); Row, Column Address: SWITCHING ¹ (A10: Low permanently); Bank Address: cycling ¹⁰ ; Data I/O: Seamless Read Data Burst : Output Data switches every clock cycle (i.e. data stable during one clock cycle); Output Buffer: Off ² ; ODT: disabled ³ ; Burst Length: BL8 ⁵ ; Active / Idle Banks: All / none ¹⁰ ; Pattern: R0 D DD R1 D DD R2 D DD R3 D DD R4 ⁴
IDD4W	Operating Burst Write Current CKE=High; External Clock=On; tCK, CL: see table in the next page; AL: 0; CS: High between valid Commands; Command Inputs: SWITCHING ¹ (except WR Commands); Row, Column Address: SWITCHING ¹ (A10: Low permanently); Bank Address: cycling ¹⁰ ; Data I/O: Seamless Write Data Burst : Input Data switches every clock cycle (i.e. data stable during one clock cycle); DM: L permanently; Output Buffer: Off ² ; ODT: disabled ³ ; Burst Length: BL8 ⁵ ; Active / Idle Banks: All / none ¹⁰ ; Pattern: W0 D DD W1 D DD W2 D DD W3 D DD W4 ⁴
IDD5B	Burst Refresh Current CKE=High; External Clock=On; tCK, tRFC: see table in the next page; CS: High between valid Commands; Command Inputs, Row, Column, Bank Addresses, Data I/O: SWITCHING ¹ ; Output Buffer: Off ² ; ODT: disabled ³ ; Active Banks: Refresh Command every tRFC=tRFC(IDD); Idle banks: none.
IDD6	Self-Refresh Current Tcase=0-85°C; Auto Self Refresh =Disable; Self Refresh Temperature Range=Normal ⁹ ; CKE=Low; External Clock=Off (CK and CK: Low); CS, Command Inputs, Row, Column Address, Bank Address, Data I/O: Floating; Output Buffer: off ² ; ODT: disabled ³ ; Active Banks: All (during Self-Refresh action); Idle Banks: all (between Self-Rerefresh actions)
IDD6ET	Self-Refresh Current: extended temperature range Tcase=0-95°C; Auto Self Refresh =Disable; Self Refresh Temperature Range=Extended ⁹ ; CKE=Low; External Clock=Off (CK and CK: Low); CS, Command Inputs, Row, Column Address, Bank Address, Data I/O: Floating; Output Buffer: off ² ; ODT: disabled ³ ; Active Banks: All (during Self-Refresh action); Idle Banks: all (between Self-Rerefresh actions)
IDD6TC	Auto Self-Refresh Current Tcase=0-95°C; Auto Self Refresh =Enable ⁸ ; Self Refresh Temperature Range=Normal ⁹ ; CKE=Low; External Clock=Off (CK and CK: Low); CS, Command Inputs, Row, Column Address, Bank Address, Data I/O: Floating; Output Buffer: off ² ; ODT: disabled ³ ; Active Banks: All (during Self-Refresh action); Idle Banks: all (between Self-Rerefresh actions)
IDD7	Operating Bank Interleave Read Current CKE=High; External Clock=On; tCK, tRC, tRAS, tRCD, tRRD, CL: see table as below; AL=tRCD.min-tCK; CS=High between valid commands; Command Input: see table; Row, Column Address: Stable during DESELECT; Bank Address: cycling ¹⁰ ; Data I/O: Read Data: Output Data switches every clock cycle (i.e. data stable during one clock cycle); Output Buffer: Off ² ; ODT: disabled ³ ; Burst Length: BL8; Active / Idle Banks: All ¹⁰ / none.

Note1: SWITCHING for Address and Command Input Signals as described in Definition of SWITCHING for Address and Command Input Signals Table.
 Note2: Output Buffer off: set MR1 A[12] = 1
 Note3: ODT disable: set MR1 A[9,6,2]=000 and MR2 A[10,9]=00
 Note4: Definition of D and D: described in Definition of SWITCHING for Address and Command Input Signals Table; Ax/Rx/Wx: Activate/Read/Write to Bank x.
 Note5: BL8 fixed by MRS: set MR0 A[1,0]=00
 Note6: Precharge Power Down Mode: set MR0 A12=0/1 for Slow/Fast Exit
 Note7: Because it is an exit after precharge power down, the valid commands are: ACT, REF, MRS, Enter Self-Refresh.
 Note8: Auto Self-Refresh(ASR): set MR2 A6 = 0/1 to disable/enable feature
 Note9: Self-Refresh Temperature Range (SRT): set MR2 A7 = 0/1 for normal/extended temperature range
 Note10: Cycle banks as follows: 0,1,2,3,...,7,0,1,...

For ID testing the following parameters are utilized.

For testing the IDD parameters, the following timing parameters are used:

Parameter	Symbol	DDR3-800		DDR3-1066	DDR3-1333	DDR3-1600	Unit	
		-5-5-5	-6-6-6	-7-7-7	-9-9-9	-11-11-11		
Clock Cycle Time	tCKmin(IDD)	2.5	2.5	1.875	1.5	1.25	ns	
CAS Latency	CL(IDD)	5	6	7	9	11	nCK	
Active to Read or Write delay	tRCDmin(IDD)	12.5	15	13.125	12	13.125	ns	
Active to Active / Auto-Refresh command period	tRCmin(IDD)	50	52.5	50.63	48	48.125	ns	
Active to Precharge Command	tRASmin(IDD)	37.5	37.5	37.5	36	35	ns	
Precharge Command Period	tRPmin(IDD)	12.5	15	13.13	12	13.75	ns	
Four activate window	tFAW(IDD)	1kB	40	40	37.5	30	30	ns
		2kB	50	50	50	45	40	ns
Active to Active command period	tRRD(IDD)	1kB	10	10	7.5	6	6	nCK
		2kB	10	10	10	7.5	7.5	nCK
Auto-Refresh to Active / Auto-Refresh command period	tRFC(IDD)	160	160	160	160	160	ns	

Definition of SWITCHING for Address and Command Input Signals

SWITCHING for Address (row, column) and Command Signals (CS, RAS, CAS, WE) is defined as:	
Address (row, column)	<p>If not otherwise mentioned the inputs are stable at HIGH or LOW during 4 clocks and change then to the opposite value (e.g. Ax Ax Ax Ax \overline{Ax} \overline{Ax} \overline{Ax} \overline{Ax} Ax Ax Ax Ax... Please see each IDDx definition for details</p>
Bank Address	<p>If not otherwise mentioned the bank addresses should be switched like the row/column address - please see each IDDx for details</p>
Command (\overline{CS} , \overline{RAS} , \overline{CAS} , \overline{WE})	<p>Define D = {\overline{CS}, \overline{RAS}, \overline{CAS}, \overline{WE}} := {HIGH, LOW, LOW, LOW} Define D = {\overline{CS}, \overline{RAS}, \overline{CAS}, \overline{WE}} := {HIGH, HIGH, HIGH, HIGH} Define Command Background Pattern = D D \overline{D} \overline{D} D D \overline{D} \overline{D} D D \overline{D} \overline{D}... If other commands are necessary (e.g. ACT for IDD0 or Read for IDD4R), the Background Pattern Command is substituted by the respective \overline{CS}, \overline{RAS}, \overline{CAS}, \overline{WE} levels of the necessary command. See each IDDx definition for details.</p>

Standard Speed Bins

DDR3-1600MHz

Speed Bin		DDR3-1600		Unit	
CL-nRCD-nRP		11-11-11			
Parameter	Symbol	Min	Max		
Internal read command to first data	tAA	13.750 (13.125) _{5,11}	20.000	ns	
ACT to internal read or write delay time	tRCD	13.750 (13.125) _{5,11}	-	ns	
PRE command period	tRP	13.750 (13.125) _{5,11}	-	ns	
ACT to ACT or REF command period	tRC	48.750 (48.125) _{5,11}	-	ns	
ACT to PRE command period	tRAS	35.000	9*tREFI	ns	
CL=5	CWL =5	tCK(AVG)	3.000	3.300	ns
	CWL =6	tCK(AVG)	Reserved	Reserved	ns
	CWL =7	tCK(AVG)	Reserved	Reserved	ns
	CWL =8	tCK(AVG)	Reserved	Reserved	ns
CL=6	CWL =5	tCK(AVG)	2.500	3.300	ns
	CWL =6	tCK(AVG)	Reserved	Reserved	ns
	CWL =7	tCK(AVG)	Reserved	Reserved	ns
	CWL =8	tCK(AVG)	Reserved	Reserved	ns
CL=7	CWL =5	tCK(AVG)	Reserved	Reserved	ns
	CWL =6	tCK(AVG)	1.875	<2.5	ns
	CWL =7	tCK(AVG)	Reserved	Reserved	ns
	CWL =8	tCK(AVG)	Reserved	Reserved	ns
CL=8	CWL =5	tCK(AVG)	Reserved	Reserved	ns
	CWL =6	tCK(AVG)	1.875	<2.5	ns
	CWL =7	tCK(AVG)	Reserved	Reserved	ns
	CWL =8	tCK(AVG)	Reserved	Reserved	ns
CL=9	CWL =5	tCK(AVG)	Reserved	Reserved	ns
	CWL =6	tCK(AVG)	Reserved	Reserved	ns
	CWL =7	tCK(AVG)	1.500	<1.875	ns
	CWL =8	tCK(AVG)	Reserved	Reserved	ns
CL=10	CWL =5	tCK(AVG)	Reserved	Reserved	ns
	CWL =6	tCK(AVG)	Reserved	Reserved	ns
	CWL =7	tCK(AVG)	1.500	<1.875	ns
	CWL =8	tCK(AVG)	1.250	<1.5	ns
CL=11	CWL =5	tCK(AVG)	Reserved	Reserved	ns
	CWL =6	tCK(AVG)	Reserved	Reserved	ns
	CWL =7	tCK(AVG)	Reserved	Reserved	ns
	CWL =8	tCK(AVG)	1.250*	<1.5*	ns
Supported CL Settings		6,7,8,9,10,(11)		nCK	
Supported CWL Settings		5,6,7,8		nCK	
*: Optional					

DDR3-1333MHZ

Speed Bin		DDR3-1333		Unit	
CL-nRCD-nRP		9-9-9 (-CG)			
Parameter	Symbol	Min	Max		
Internal read command to first data	tAA	13.125	20.000	ns	
ACT to internal read or write delay time	tRCD	13.125	-	ns	
PRE command period	tRP	13.125	-	ns	
ACT to ACT or REF command period	tRC	49.125	-	ns	
ACT to PRE command period	tRAS	36.000	9*tREFI	ns	
CL=5	CWL=5	tCK(AVG)	3.000	3.300	ns
	CWL=6	tCK(AVG)	Reserved	Reserved	ns
	CWL=7	tCK(AVG)	Reserved	Reserved	ns
CL=6	CWL=5	tCK(AVG)	2.500	3.300	ns
	CWL=6	tCK(AVG)	Reserved	Reserved	ns
	CWL=7	tCK(AVG)	Reserved	Reserved	ns
CL=7	CWL=5	tCK(AVG)	Reserved	Reserved	ns
	CWL=6	tCK(AVG)	1.875*	<2.5*	ns
	CWL=7	tCK(AVG)	Reserved	Reserved	ns
CL=8	CWL=5	tCK(AVG)	Reserved	Reserved	ns
	CWL=6	tCK(AVG)	1.875	<2.5	ns
	CWL=7	tCK(AVG)	Reserved	Reserved	ns
CL=9	CWL=5	tCK(AVG)	Reserved	Reserved	ns
	CWL=6	tCK(AVG)	Reserved	Reserved	ns
	CWL=7	tCK(AVG)	1.500	<1.875	ns
CL=10	CWL=5	tCK(AVG)	Reserved	Reserved	ns
	CWL=6	tCK(AVG)	Reserved	Reserved	ns
	CWL=7	tCK(AVG)	1.500*	<1.875*	ns
Supported CL Settings		6,7,8,9,(10)		nCK	
Supported CWL Settings		5,6,7		nCK	

Electrical Characteristics & AC Timing

Timing Parameter by Speed Bin (DDR3-800, 1066MHz)

Parameter	Symbol	DDR3-800		DDR3-1066		Units	Notes
		Min.	Max.	Min.	Max.		
Clock Timing							
Minimum Clock Cycle Time (DLL off mode)	tCK (DLL_OFF)	8	-	8	-	ns	
Average Clock Period	tCK(avg)	Refer to "Standard Speed Bins"				ps	
Average high pulse width	tCH(avg)	0.47	0.53	0.47	0.53	tCK(avg)	
Average low pulse width	tCL(avg)	0.47	0.53	0.47	0.53	tCK(avg)	
Absolute Clock Period	tCK(abs)	Min.: tCK(avg)min + tJIT(per)min Max.: tCK(avg)max + tJIT(per)max				ps	
Absolute clock HIGH pulse width	tCH(abs)	0.43	-	0.43	-	tCK(avg)	
Absolute clock LOW pulse width	tCL(abs)	0.43	-	0.43	-	tCK(avg)	
Clock Period Jitter	JIT(per)	-100	100	-90	90	ps	
Clock Period Jitter during DLL locking period	JIT(per, lck)	-90	90	-80	80	ps	
Cycle to Cycle Period Jitter	tJIT(cc)	200	200	180	180	ps	
Cycle to Cycle Period Jitter during DLL locking period	JIT(cc, lck)	180	180	160	160	ps	
Duty Cycle Jitter	tJIT(duty)	-	-	-	-	ps	
Cumulative error across 2 cycles	tERR(2per)	-147	147	-132	132	ps	
Cumulative error across 3 cycles	tERR(3per)	-175	175	-157	157	ps	
Cumulative error across 4 cycles	tERR(4per)	-194	194	-175	175	ps	
Cumulative error across 5 cycles	tERR(5per)	-209	209	-188	188	ps	
Cumulative error across 6 cycles	tERR(6per)	-222	222	-200	200	ps	
Cumulative error across 7 cycles	tERR(7per)	-232	232	-209	209	ps	
Cumulative error across 8 cycles	tERR(8per)	-241	241	-217	217	ps	
Cumulative error across 9 cycles	tERR(9per)	-249	249	-224	224	ps	
Cumulative error across 10 cycles	tERR(10per)	-257	257	-231	231	ps	
Cumulative error across 11 cycles	tERR(11per)	-263	263	-237	237	ps	
Cumulative error across 12 cycles	tERR(12per)	-269	269	-242	242	ps	
Cumulative error across n = 13, 14 . . . 49, 50 cycles	tERR(nper)	tERR(nper)min = (1 + 0.68ln(n)) * tJIT(per)min tERR(nper)max = (1 + 0.68ln(n)) * tJIT(per)max				ps	
Data Timing							
DQS, DQS# to DQ skew, per group, per access	tDQSQ	-	200	-	150	ps	
DQ output hold time from DQS, DQS#	tQH	0.38	-	0.38	-	tCK(avg)	
DQ low-impedance time from CK, CK#	tLZ(DQ)	-800	400	-600	300	ps	
DQ high impedance time from CK, CK#	tHZ(DQ)	-	400	-	300	ps	
Data setup time to DQS, DQS# referenced to Vih(ac) / Vil(ac) levels	tDS(base) AC175	75		25		ps	
Data setup time to DQS, DQS# referenced to Vih(ac) / Vil(ac) levels	tDS(base) AC150	125		75		ps	
Data hold time from DQS, DQS# referenced to Vih(dc) / Vil(dc) levels	tDH(base) DC100	150		100		ps	
DQ and DM Input pulse width for each input	tDIPW	600		490		ps	
Data Strobe Timing							
DQS, DQS# differential READ Preamble	tRPRE	0.9	Note 19	0.9	Note 19	tCK(avg)	
DQS, DQS# differential READ Postamble	tRPST	0.3	Note 11	0.3	Note 11	tCK(avg)	
DQS, DQS# differential output high time	tQSH	0.38	-	0.38	-	tCK(avg)	
DQS, DQS# differential output low time	tQSL	0.38	-	0.38	-	tCK(avg)	
DQS, DQS# differential WRITE Preamble	tWPRE	0.9	-	0.9	-	tCK(avg)	
DQS, DQS# differential WRITE Postamble	tWPST	0.3	-	0.3	-	tCK(avg)	
DQS, DQS# rising edge output access time from rising CK, CK#	tDQSCK	-400	400	-300	300	tCK(avg)	
DQS and DQS# low-impedance time (Referenced from RL - 1)	tLZ(DQS)	-800	400	-600	300	tCK(avg)	
DQS and DQS# high-impedance time (Referenced from RL + BL/2)	tHZ(DQS)	-	400	-	300	tCK(avg)	
DQS, DQS# differential input low pulse width	tDQSL	0.45	0.55	0.45	0.55	tCK(avg)	
DQS, DQS# differential input high pulse width	tDQSH	0.45	0.55	0.45	0.55	tCK(avg)	
DQS, DQS# rising edge to CK, CK# rising edge	tDQSS	-0.25	0.25	-0.25	0.25	tCK(avg)	
DQS, DQS# falling edge setup time to CK, CK# rising edge	tDSS	0.2	-	0.2	-	tCK(avg)	
DQS, DQS# falling edge hold time from CK, CK# rising edge	tDSH	0.2	-	0.2	-	tCK(avg)	
Command and Address Timing							

DLL locking time	tDLLK	512	-	512	-	nCK	
Internal READ Command to PRECHARGE Command delay	tRTP	tRTPmin.: max(4nCK, 7.5ns)		tRTPmax.: -			
Delay from start of internal write transaction to internal read command	tWTR	tWTRmin.: max(4nCK, 7.5ns)		tWTRmax.:			
WRITE recovery time	tWR	15	-	15	-	ns	
Mode Register Set command cycle time	tMRD	4	-	4	-	nCK	
Mode Register Set command update delay	tMOD	tMODmin.: max(12nCK, 15ns)		tMODmax.:			
ACT to internal read or write delay time	tRCD						
PRE command period	tRP						
ACT to ACT or REF command period	tRC						
CAS# to CAS# command delay	tCCD	4	-	4	-	nCK	
Auto precharge write recovery + precharge time	tDAL(min)	WR + roundup(tRP / tCK(avg))				nCK	
Multi-Purpose Register Recovery Time	tMPRR	1	-	1	-	nCK	
ACTIVE to PRECHARGE command period	tRAS	Standard Speed Bins					
ACTIVE to ACTIVE command period for 1KB page size	tRRD	max(4nCK, 10ns)	-	max(4nCK, 7.5ns)	-		
ACTIVE to ACTIVE command period for 2KB page size	tRRD	tRRDmin.: max(4nCK, 10ns)		tRRDmax.:			
Four activate window for 1KB page size	tFAW	40	-	37.5	-	ns	
Four activate window for 2KB page size	tFAW	50	-	50	-	ns	
Command and Address setup time to CK, CK# referenced to Vih(ac) / Vil(ac) levels	tIS(base)	200	-	125	-	ps	
Command and Address hold time from CK, CK# referenced to Vih(dc) / Vil(dc) levels	tIH(base)	275	-	200	-	ps	
Command and Address setup time to CK, CK# referenced to Vih(ac) / Vil(ac) levels	tIS(base) AC150	200+150	-	125+150	-	ps	
Control and Address Input pulse width for each input	tIPW	900	-	780	-	ps	
Calibration Timing							
Power-up and RESET calibration time	tZQinit	512	-	512	-	nCK	
Normal operation Full calibration time	tZQoper	256	-	256	-	nCK	
Normal operation Short calibration time	tZQCS	64	-	64	-	nCK	
Reset Timing							
Exit Reset from CKE HIGH to a valid command	tXPR	tXPRmin.: max(5nCK, tRFC(min) + 10ns)		tXPRmax.: -			
Self Refresh Timings							
Exit Self Refresh to commands not requiring a locked DLL	tXS	tXSmin.: max(5nCK, tRFC(min) + 10ns)		tXSmax.: -			
Exit Self Refresh to commands requiring a locked DLL	tXSDLL	tXSDLLmin.: tDLLK(min)		tXSDLLmax.: -		nCK	
Minimum CKE low width for Self Refresh entry to exit timing	tCKESR	tCKESRmin.: tCKE(min) + 1 nCK		tCKESRmax.: -			
Valid Clock Requirement after Self Refresh Entry (SRE) or Power-Down Entry (PDE)	tCKSRE	tCKSREmin.: max(5 nCK, 10 ns)		tCKSREmax.: -			
Valid Clock Requirement before Self Refresh Exit (SRX) or Power-Down Exit (PDX) or Reset Exit	tCKSRX	tCKSRXmin.: max(5 nCK, 10 ns)		tCKSRXmax.: -			
Power Down Timings							
Exit Power Down with DLL on to any valid command; Exit Precharge Power Down with DLL frozen to commands not requiring a locked DLL	tXP	tXPmin.: max(3nCK, 7.5ns)		tXPmax.: -			
Exit Precharge Power Down with DLL frozen to commands requiring a locked DLL	tXPDLL	tXPDLLmin.: max(10nCK, 24ns)		tXPDLLmax.: -			
CKE minimum pulse width	tCKE	tCKEmin.: max(3nCK 7.5ns)		tCKEmin.: max(3nCK 5.625ns)		tCKEmax.: -	
Command pass disable delay	tCPDED	tCPDEDmin.: 1		tCPDEDmin.: -		nCK	
Power Down Entry to Exit Timing	tPD	tPDmin.: tCKE(min)		tPDmax.: 9*tREFI			
Timing of ACT command to Power Down entry	tACTPDEN	tACTPDENmin.: 1		tACTPDENmax.: -		nCK	
Timing of PRE or PREA command to Power Down entry	tPRPDEN	tPRPDENmin.: 1		tPRPDENmax.: -		nCK	
Timing of RD/RDA command to Power Down entry	tRDPDEN	tRDPDENmin.: RL+4+1				nCK	

		tRDPDENmax.: -					
Timing of WR command to Power Down entry (BL8OTF, BL8MRS, BC4OTF)	tWRPDEN	tWRPDENmin.: WL + 4 + (tWR / tCK(avg)) tWRPDENmax.: -				nCK	
Timing of WRA command to Power Down entry (BL8OTF, BL8MRS, BC4OTF)	tWRAPDEN	tWRAPDENmin.: WL+4+WR+1 tWRAPDENmax.: -				nCK	
Timing of WR command to Power Down entry (BC4MRS)	tWRPDEN	tWRPDENmin.: WL + 2 + (tWR / tCK(avg)) tWRPDENmax.: -				nCK	
Timing of WRA command to Power Down entry (BC4MRS)	tWRAPDEN	tWRAPDENmin.: WL + 2 +WR + 1 tWRAPDENmax.: -				nCK	
Timing of REF command to Power Down entry	tREFPDEN	tREFPDENmin.: 1 tREFPDENmax.: -				nCK	
Timing of MRS command to Power Down entry	tMRSPDEN	tMRSPDENmin.: tMOD(min) tMRSPDENmax.: -					
ODT Timings							
ODT high time without write command or with write command and BC4	ODTH4	ODTH4min.: 4 ODTH4max.: -				nCK	
ODT high time with Write command and BL8	ODTH8	ODTH8min.: 6 ODTH8max.: -				nCK	
Asynchronous RTT turn-on delay (Power-Down with DLL frozen)	tAONPD	2	8.5	2	8.5	ns	
Asynchronous RTT turn-off delay (Power-Down with DLL frozen)	tAOFPD	2	8.5	2	8.5	ns	
RTT turn-on	tAON	-400	400	-300	300	ps	
RTT_Nom and RTT_WR turn-off time from ODTLoff reference	tAOF	0.3	0.7	0.3	0.7	tCK(avg)	
RTT dynamic change skew	tADC	0.3	0.7	0.3	0.7	tCK(avg)	
Write Leveling Timings							
First DQS/DQS# rising edge after write leveling mode is programmed	tWLMRD	40	-	40	-	nCK	
DQS/DQS# delay after write leveling mode is programmed	tWLDQSEN	25	-	25	-	nCK	
Write leveling setup time from rising CK, CK# crossing to rising DQS, DQS# crossing	tWLS	325	-	245	-	ps	
Write leveling hold time from rising DQS, DQS# crossing to rising CK, CK# crossing	tWLH	325	-	245	-	ps	
Write leveling output delay	tWLO	0	9	0	9	ns	
Write leveling output error	tWLOE	0	2	0	2	ns	

Timing Parameter by Speed Bin (DDR3-1333, 1600MHz)

Parameter	Symbol	DDR3-1333		DDR3-1600		Units	Notes
		Min.	Max.	Min.	Max.		
Clock Timing							
Minimum Clock Cycle Time (DLL off mode)	tCK (DLL_OFF)	8	-	8	-	ns	
Average Clock Period	tCK(avg)	Refer to "Standard Speed Bins"				ps	
Average high pulse width	tCH(avg)	0.47	0.53	0.47	0.53	tCK(avg)	
Average low pulse width	tCL(avg)	0.47	0.53	0.47	0.53	tCK(avg)	
Absolute Clock Period	tCK(abs)	Min.: tCK(avg)min + tJIT(per)min Max.: tCK(avg)max + tJIT(per)max				ps	
Absolute clock HIGH pulse width	tCH(abs)	0.43	-	0.43	-	tCK(avg)	
Absolute clock LOW pulse width	tCL(abs)	0.43	-	0.43	-	tCK(avg)	
Clock Period Jitter	JIT(per)	-80	80	-70	70	ps	
Clock Period Jitter during DLL locking period	JIT(per, lck)	-70	70	-60	60	ps	
Cycle to Cycle Period Jitter	tJIT(cc)	160	160	140	140	ps	
Cycle to Cycle Period Jitter during DLL locking period	JIT(cc, lck)	140	140	120	120	ps	
Duty Cycle Jitter	tJIT(duty)	-	-	-	-	ps	
Cumulative error across 2 cycles	tERR(2per)	-118	118	-103	103	ps	
Cumulative error across 3 cycles	tERR(3per)	-140	140	-122	122	ps	
Cumulative error across 4 cycles	tERR(4per)	-155	155	-136	136	ps	
Cumulative error across 5 cycles	tERR(5per)	-168	168	-147	147	ps	
Cumulative error across 6 cycles	tERR(6per)	-177	177	-155	155	ps	
Cumulative error across 7 cycles	tERR(7per)	-186	186	-163	163	ps	
Cumulative error across 8 cycles	tERR(8per)	-193	193	-169	169	ps	
Cumulative error across 9 cycles	tERR(9per)	-200	200	-175	175	ps	
Cumulative error across 10 cycles	tERR(10per)	-205	205	-180	180	ps	
Cumulative error across 11 cycles	tERR(11per)	-210	210	-184	184	ps	
Cumulative error across 12 cycles	tERR(12per)	-215	215	-188	188	ps	
Cumulative error across n = 13, 14 . . . 49, 50 cycles	tERR(nper)	tERR(nper)min = (1 + 0.68ln(n)) * tJIT(per)min tERR(nper)max = (1 + 0.68ln(n)) * tJIT(per)max				ps	
Data Timing							
DQS, DQS# to DQ skew, per group, per access	tDQSQ	-	125	-	100	ps	
DQ output hold time from DQS, DQS#	tQH	0.38	-	0.38	-	tCK(avg)	
DQ low-impedance time from CK, CK#	tLZ(DQ)	-500	250	-450	225	ps	
DQ high impedance time from CK, CK#	tHZ(DQ)	-	250	-	225	ps	
Data setup time to DQS, DQS# referenced to Vih(ac) / Vil(ac) levels	tDS(base) AC175	-	-	-	-	ps	
Data setup time to DQS, DQS# referenced to Vih(ac) / Vil(ac) levels	tDS(base) AC150	30	-	10	-	ps	
Data hold time from DQS, DQS# referenced to Vih(dc) / Vil(dc) levels	tDH(base) DC100	65	-	45	-	ps	
DQ and DM Input pulse width for each input	tDIPW	400	-	360	-	ps	
Data Strobe Timing							
DQS,DQS# differential READ Preamble	tRPRE	0.9	Note 19	0.9	Note 19	tCK(avg)	
DQS, DQS# differential READ Postamble	tRPST	0.3	Note 11	0.3	Note 11	tCK(avg)	
DQS, DQS# differential output high time	tQSH	0.4	-	0.4	-	tCK(avg)	
DQS, DQS# differential output low time	tQSL	0.4	-	0.4	-	tCK(avg)	
DQS, DQS# differential WRITE Preamble	tWPRE	0.9	-	0.9	-	tCK(avg)	
DQS, DQS# differential WRITE Postamble	tWPST	0.3	-	0.3	-	tCK(avg)	
DQS, DQS# rising edge output access time from rising CK, CK#	tDQSCK	-255	255	-225	225	tCK(avg)	
DQS and DQS# low-impedance time (Referenced from RL - 1)	tLZ(DQS)	-500	250	-450	225	tCK(avg)	
DQS and DQS# high-impedance time (Referenced from RL + BL/2)	tHZ(DQS)	-	250	-	225	tCK(avg)	
DQS, DQS# differential input low pulse width	tDQSL	0.45	0.55	0.45	0.55	tCK(avg)	
DQS, DQS# differential input high pulse width	tDQSH	0.45	0.55	0.45	0.55	tCK(avg)	
DQS, DQS# rising edge to CK, CK# rising edge	tDQSS	-0.25	0.25	-0.27	0.27	tCK(avg)	
DQS, DQS# falling edge setup time to CK, CK# rising edge	tDSS	0.2	-	0.18	-	tCK(avg)	
DQS, DQS# falling edge hold time from CK, CK# rising edge	tDSH	0.2	-	0.18	-	tCK(avg)	
Command and Address Timing							

DLL locking time	tDLLK	512	-	512	-	nCK	
Internal READ Command to PRECHARGE Command delay	tRTP	tRTPmin.: max(4nCK, 7.5ns)		tRTPmax.: -			
Delay from start of internal write transaction to internal read command	tWTR	tWTRmin.: max(4nCK, 7.5ns)		tWTRmax.: -			
WRITE recovery time	tWR	15	-	15	-	ns	
Mode Register Set command cycle time	tMRD	4	-	4	-	nCK	
Mode Register Set command update delay	tMOD	tMODmin.: max(12nCK, 15ns)		tMODmax.: -			
ACT to internal read or write delay time	tRCD						
PRE command period	tRP						
ACT to ACT or REF command period	tRC						
CAS# to CAS# command delay	tCCD	4	-	4	-	nCK	
Auto precharge write recovery + precharge time	tDAL(min)	WR + roundup(tRP / tCK(avg))				nCK	
Multi-Purpose Register Recovery Time	tMPRR	1	-	1	-	nCK	
ACTIVE to PRECHARGE command period	tRAS	Standard Speed Bins					
ACTIVE to ACTIVE command period for 1KB page size	tRRD	tRRDmin.: max(4nCK, 6ns)		tRRDmax.: -			
ACTIVE to ACTIVE command period for 2KB page size	tRRD	tRRDmin.: max(4nCK, 7.5ns)		tRRDmax.: -			
Four activate window for 1KB page size	tFAW	30	0	30	-	ns	
Four activate window for 2KB page size	tFAW	45	0	40	-	ns	
Command and Address setup time to CK, CK# referenced to Vih(ac) / Vil(ac) levels	tIS(base)	65	-	45	-	ps	
Command and Address hold time from CK, CK# referenced to Vih(dc) / Vil(dc) levels	tIH(base)	140	-	120	-	ps	
Command and Address setup time to CK, CK# referenced to Vih(ac) / Vil(ac) levels	tIS(base) AC150	65+125	-	170	-	ps	
Control and Address Input pulse width for each input	tIPW	620	-	560	-	ps	
Calibration Timing							
Power-up and RESET calibration time	tZQinit	512	-	512	-	nCK	
Normal operation Full calibration time	tZQoper	256	-	256	-	nCK	
Normal operation Short calibration time	tZQCS	64	-	64	-	nCK	
Reset Timing							
Exit Reset from CKE HIGH to a valid command	tXPR	tXPRmin.: max(5nCK, tRFC(min) + 10ns)		tXPRmax.: -			
Self Refresh Timings							
Exit Self Refresh to commands not requiring a locked DLL	tXS	tXSmin.: max(5nCK, tRFC(min) + 10ns)		tXSmax.: -			
Exit Self Refresh to commands requiring a locked DLL	tXSDLL	tXSDLLmin.: tDLLK(min)		tXSDLLmax.: -		nCK	
Minimum CKE low width for Self Refresh entry to exit timing	tCKESR	tCKESRmin.: tCKE(min) + 1 nCK		tCKESRmax.: -			
Valid Clock Requirement after Self Refresh Entry (SRE) or Power-Down Entry (PDE)	tCKSRE	tCKSREmin.: max(5 nCK, 10 ns)		tCKSREmax.: -			
Valid Clock Requirement before Self Refresh Exit (SRX) or Power-Down Exit (PDX) or Reset Exit	tCKSRX	tCKSRXmin.: max(5 nCK, 10 ns)		tCKSRXmax.: -			
Power Down Timings							
Exit Power Down with DLL on to any valid command; Exit Precharge Power Down with DLL frozen to commands not requiring a locked DLL	tXP	tXPmin.: max(3nCK, 6ns)		tXPmin.: max(3nCK, 6ns)			
		tXPmax.: -		tXPmax.: -			
Exit Precharge Power Down with DLL frozen to commands requiring a locked DLL	tXPDLL	tXPDLLmin.: max(10nCK, 24ns)		tXPDLLmax.: -			
CKE minimum pulse width	tCKE	tCKEmin.: max(3nCK, 5.625ns)		tCKEmin.: max(3nCK, 5ns)			
		tCKEmax.: -		tCKEmax.: -			
Command pass disable delay	tCPDED	tCPDEDmin.: 1		tCPDEDmin.: -		nCK	
Power Down Entry to Exit Timing	tPD	tPDmin.: tCKE(min)		tPDmax.: 9*tREFI			
Timing of ACT command to Power Down entry	tACTPDEN	tACTPDENmin.: 1		tACTPDENmax.: -		nCK	
Timing of PRE or PEA command to Power Down entry	tPRPDEN	tPRPDENmin.: 1		tPRPDENmax.: -		nCK	

Timing of RD/RDA command to Power Down entry	tRDPDEN	tRDPDENmin.: RL+4+1 tRDPDENmax.: -				nCK	
Timing of WR command to Power Down entry (BL8OTF, BL8MRS, BC4OTF)	tWRPDEN	tWRPDENmin.: WL + 4 + (tWR / tCK(avg)) tWRPDENmax.: -				nCK	
Timing of WRA command to Power Down entry (BL8OTF, BL8MRS, BC4OTF)	tWRAPDEN	tWRAPDENmin.: WL+4+WR+1 tWRAPDENmax.: -				nCK	
Timing of WR command to Power Down entry (BC4MRS)	tWRPDEN	tWRPDENmin.: WL + 2 + (tWR / tCK(avg)) tWRPDENmax.: -				nCK	
Timing of WRA command to Power Down entry (BC4MRS)	tWRAPDEN	tWRAPDENmin.: WL + 2 + WR + 1 tWRAPDENmax.: -				nCK	
Timing of REF command to Power Down entry	tREFPDEN	tREFPDENmin.: 1 tREFPDENmax.: -				nCK	
Timing of MRS command to Power Down entry	tMRSPDEN	tMRSPDENmin.: tMOD(min) tMRSPDENmax.: -					
ODT Timings							
ODT high time without write command or with write command and BC4	ODTH4	ODTH4min.: 4 ODTH4max.: -				nCK	
ODT high time with Write command and BL8	ODTH8	ODTH8min.: 6 ODTH8max.: -				nCK	
Asynchronous RTT turn-on delay (Power-Down with DLL frozen)	tAONPD	2	8.5	2	8.5	ns	
Asynchronous RTT turn-off delay (Power-Down with DLL frozen)	tAOFPD	2	8.5	2	8.5	ns	
RTT turn-on	tAON	-250	250	-225	225	ps	
RTT_Nom and RTT_WR turn-off time from ODTLoff reference	tAOF	0.3	0.7	0.3	0.7	tCK(avg)	
RTT dynamic change skew	tADC	0.3	0.7	0.3	0.7	tCK(avg)	
Write Leveling Timings							
First DQS/DQS# rising edge after write leveling mode is programmed	tWLMRD	40	-	40	-	nCK	
DQS/DQS# delay after write leveling mode is programmed	tWLDQSEN	25	-	25	-	nCK	
Write leveling setup time from rising CK, CK# crossing to rising DQS, DQS# crossing	tWLS	195	-	165	-	ps	
Write leveling hold time from rising DQS, DQS# crossing to rising CK, CK# crossing	tWLH	195	-	165	-	ps	
Write leveling output delay	tWLO	0	9	0	7.5	ns	
Write leveling output error	tWLOE	0	2	0	2	ns	

Jitter Notes

Specific Note a

Unit “tCK(avg)” represents the actual tCK(avg) of the input clock under operation. Unit “nCK” represents one clock cycle of the input clock, counting the actual clock edges. ex) tMRD=4 [nCK] means; if one Mode Register Set command is registered at Tm, another Mode Register Set command may be registered at Tm+4, even if (Tm+4-Tm) is 4 x tCK(avg) + tERR(4per), min.

Specific Note b

These parameters are measured from a command/address signal (CKE, CS, RAS, CAS, WE, ODT, BA0, A0, A1, etc) transition edge to its respective clock signal (CK/CK) crossing. The spec values are not affected by the amount of clock jitter applied (i.e. tJIT(per), tJIT(cc), etc.), as the setup and hold are relative to the clock signal crossing that latches the command/address. That is, these parameters should be met whether clock jitter is present or not.

Specific Note c

These parameters are measured from a data strobe signal (DQS(L/U), DQS(L/U)) crossing to its respective clock signal (CK, CK) crossing. The spec values are not affected by the amount of clock jitter applied (i.e. tJIT(per), tJIT(cc), etc), as these are relative to the clock signal crossing. That is, these parameters should be met whether clock jitter is present or not.

Specific Note d

These parameters are measured from a data signal (DM(L/U), DQ(L/U)0, DQ(L/U)1, etc.) transition edge to its respective data strobe signal (DQS(L/U), DQS(L/U)) crossing.

Specific Note e

For these parameters, the DDR3 SDRAM device supports $t_nPARAM [nCK] = RU\{tPARAM[ns] / tCK(avg)[ns]\}$, which is in clock cycles, assuming all input clock jitter specifications are satisfied. For example, the device will support $t_nRP = RU\{tRP/tCK(avg)\}$, which is in clock cycles, if all input clock jitter specifications are met. This means: For DDR3-800 6-6-6, of which tRP = 15ns, the device will support $t_nRP = RU\{tRP/tCK(avg)\} = 6$, as long as the input clock jitter specifications are met, i.e. Precharge command at Tm and Active command at Tm+6 is valid even if (Tm+6-Tm) is less than 15ns due to input clock jitter.

Specific Note f

When the device is operated with input clock jitter, this parameter needs to be derated by the actual tERR(mper), act of the input clock, where $2 \leq m \leq 12$. (output derating are relative to the SDRAM input clock.)

For example, if the measured jitter into a DDR3-800 SDRAM has $tERR(mper),act,min = -172ps$ and $tERR(mper),act,max = 193ps$, then $tDQSCK,min(derated) = tDQSCK,min - tERR(mper),act,max = -400ps - 193ps = -593ps$ and $tDQSCK,max(derated) = tDQSCK,max - tERR(mper),act,min = 400ps + 172ps = 572ps$. Similarly, $tLZ(DQ)$ for DDR3-800 derates to $tLZ(DQ),min(derated) = -800ps - 193ps = -993ps$ and $tLZ(DQ),max(derated) = 400ps + 172ps = 572ps$. (Caution on the min/max usage!)

Note that $tERR(mper),act,min$ is the minimum measured value of $tERR(nper)$ where $2 \leq n \leq 12$, and $tERR(mper),act,max$ is the maximum measured value of $tERR(nper)$ where $2 \leq n \leq 12$.

Specific Note g

When the device is operated with input clock jitter, this parameter needs to be derated by the actual tJIT(per),act of the input clock. (output deratings are relative to the SDRAM input clock.) For example, if the measured jitter into a DDR3-800 SDRAM has $tCK(avg),act=2500ps$, $tJIT(per),act,min = -72ps$ and $tJIT(per),act,max = 93ps$, then $tRPRE,min(derated) = tRPRE,min + tJIT(per),act,min = 0.9 \times tCK(avg),act + tJIT(per),act,min = 0.9 \times 2500ps - 72ps = 2178ps$. Similarly, $tQH,min(derated) = tQH,min + tJIT(per),act,min = 0.38 \times tCK(avg),act + tJIT(per),act,min = 0.38 \times 2500ps - 72ps = 878ps$. (Caution on the min/max usage!)

Package Dimensions (x8; 78 balls; 0.8mmx0.8mm Pitch; BGA)

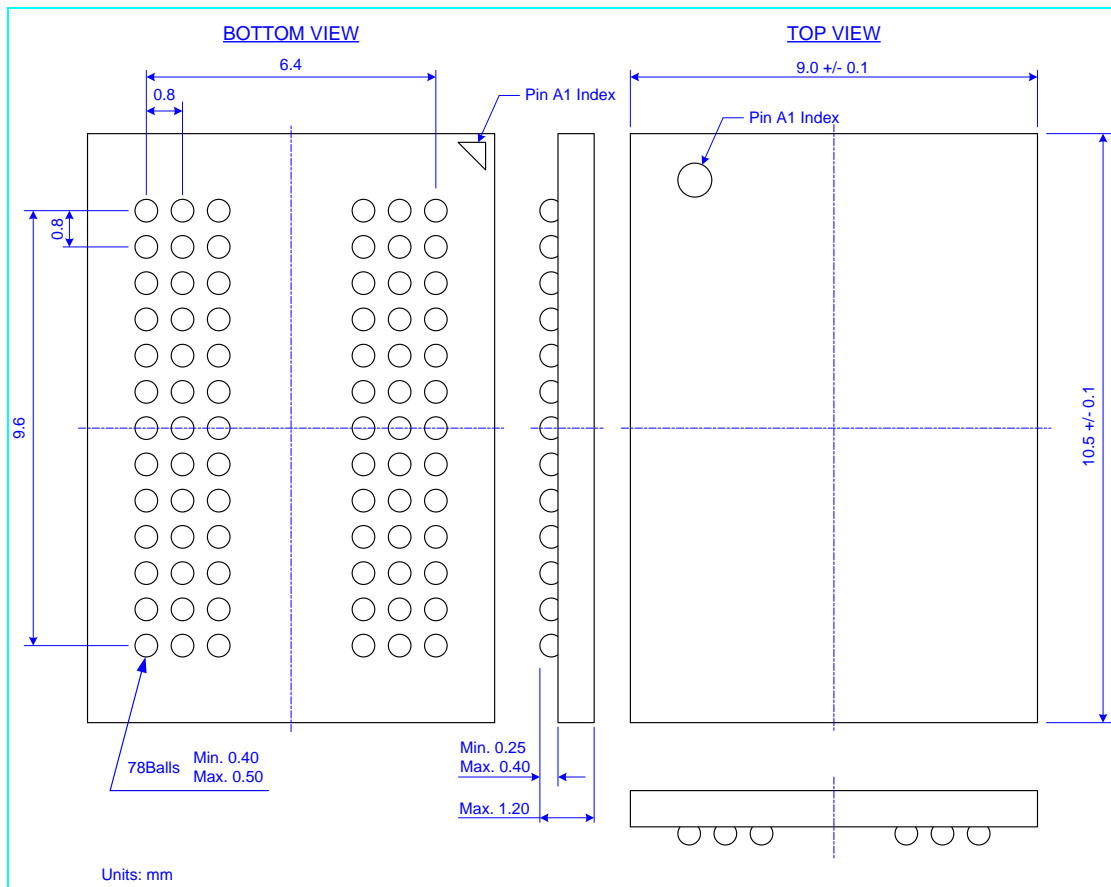

Package Dimensions (x16; 96 balls; 0.8mmx0.8mm Pitch; BGA)

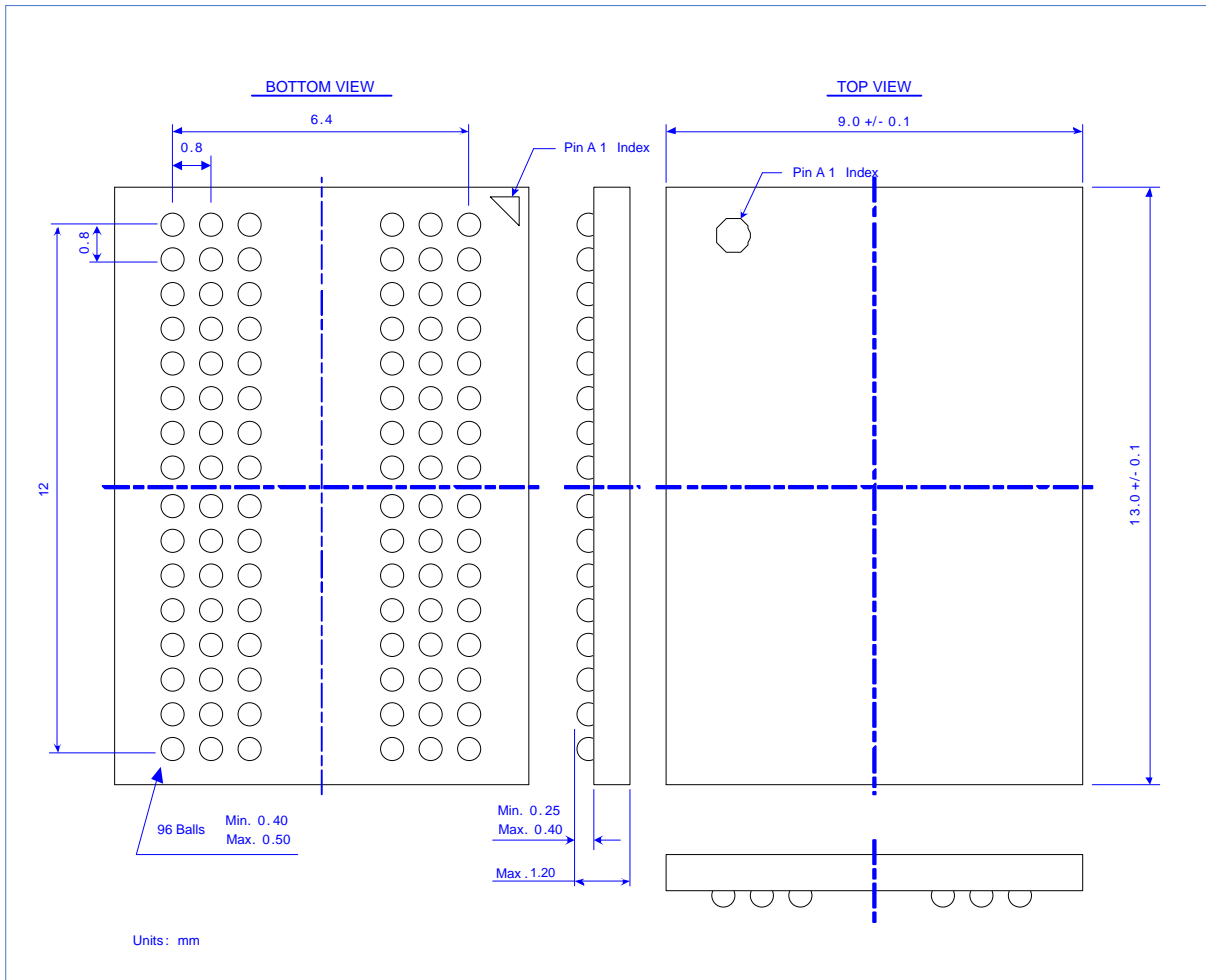

Copyright, DELSON TECHNOLOGY.

Printed in Taiwan

The information in this document is subject to change without notice.

DELSON TECH makes no commitment to update or keep current the information contained in this document. No part of this document may be copied or reproduced in any form or by any means without the prior written consent of DELSON TECH.

DELSON TECH subjects its products to normal quality control sampling techniques which are intended to provide an assurance of high quality products suitable for usual commercial applications. DELSON TECH does not do testing appropriate to provide 100% product quality assurance and does not assume any liability for consequential or incidental arising from any use of its products. If such products are to be used in applications in which personal injury might occur from failure, purchaser must do its own quality assurance testing appropriate to such applications.